



TUFFSTUFF FITNESS INTERNATIONAL OWNER'S MANUAL Maintenance & Assembly Instructions

IMPORTANT: KEEP THIS MANUAL FOR FUTURE REFERENCE



NOTICE

It is the Purchaser's/Owner's obligation:

1. To disclose and post all Rules & Regulations, Danger, Warning and Caution labels affixed on the machine to their customers/users.
2. Equipment to be installed by TFI Authorized Dealer or a service company approved by TFI.
3. Provide trained personnel, supervision and correct usage of the equipment.
4. Provide scheduled inspection, maintenance & repairs and must be performed by TFI Authorized Dealer or a service company approved by TFI.
5. Must use only genuine TuffStuff replacement parts.

HTX-2000 Dual-Stack Functional Trainer

HTX-2000_Rev0
Revision Date 4-29-14

Table of Contents



OVERHEAD SPECIFICATIONS	Page 3
DANGER, WARNING, & CAUTION LABELS INFORMATION	Page 4-7
IMPORTANT SAFETY INSTRUCTIONS.....	Page 8
REGISTRATION, SERVICE & ASSEMBLY.....	Page 9
INSPECTION/MAINTENANCE.....	Page 10
CABLE INSPECTION.....	Page 11
STEP 1	Page 12
STEP 2	Page 13
STEP 3	Page 14
STEP 4	Page 15
STEP 5	Page 16
STEP 6	Page 17
STEP 7	Page 18
STEP 8	Page 19
STEP 9	Page 20
STEP 10.....	Page 21
STEP 11	Page 22
STEP 12 LAT CABLE ROUTING.....	Page 23-24
STEP 13 LOW ROW CABLE ROUTING	Page 25
STEP 14 LOW ROW CABLE ROUTING	Page 26
STEP 15 LEG EXTENSION CABLE ROUTING.....	Page 27
STEP 16.....	Page 28
STEP 17.....	Page 29
STEP 18.....	Page 30
STEP 19.....	Page 31
PARTS LIST	Page 32
EXPLODED VIEW	Page 33
BASIC EXERCISE GUIDE.....	Page 34-37
NOTES.....	Page 38
WARRANTY	Page 39

TuffStuff Fitness International Inc. continually engages in research related to product improvements. Please take the time to carefully read through this owner's manual thoroughly. Instructions contained in this owner's manual are not intended to cover all details or variations possible with equipment, or to cover every contingency that may be met in conjunction with assembly, installation, operation, maintenance or troubleshooting of the equipment. Even though we have prepared this owner's manual with extreme care, neither the manufacturer nor the author can accept responsibility for any errors in, or omission from, the information given. Should additional information be required, or should situations arise that are not covered by this owner's manual, the matter should be directed to Customer Service at TuffStuff Fitness International Inc. in Chino, California.

Overhead Specifications

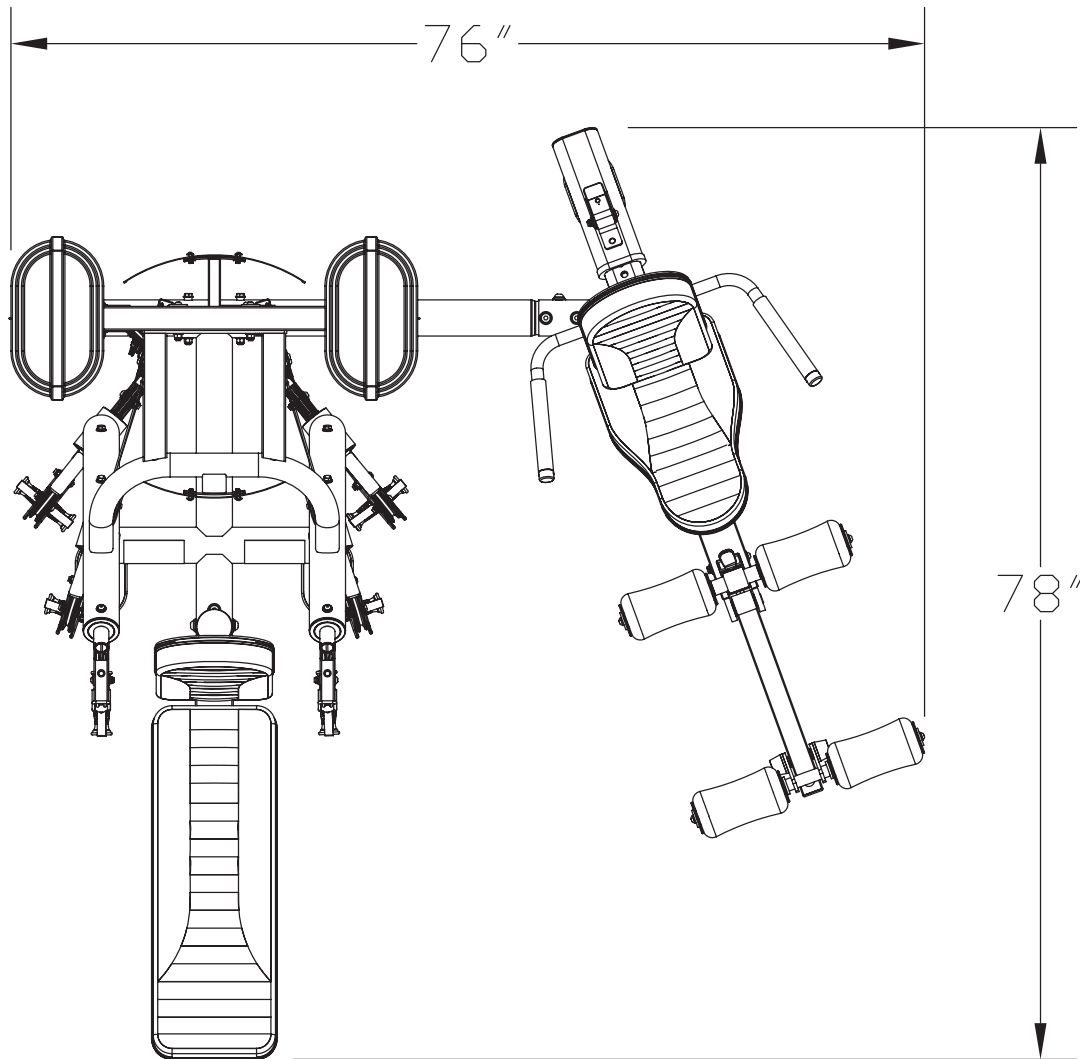

L 78" X W 76" X H 77"
PRODUCT WEIGHT 645 lbs
MAX-LOAD WEIGHT LIMIT - 400 lbs

Carefully read ALL Danger, Warning & Caution labels posted on the machine

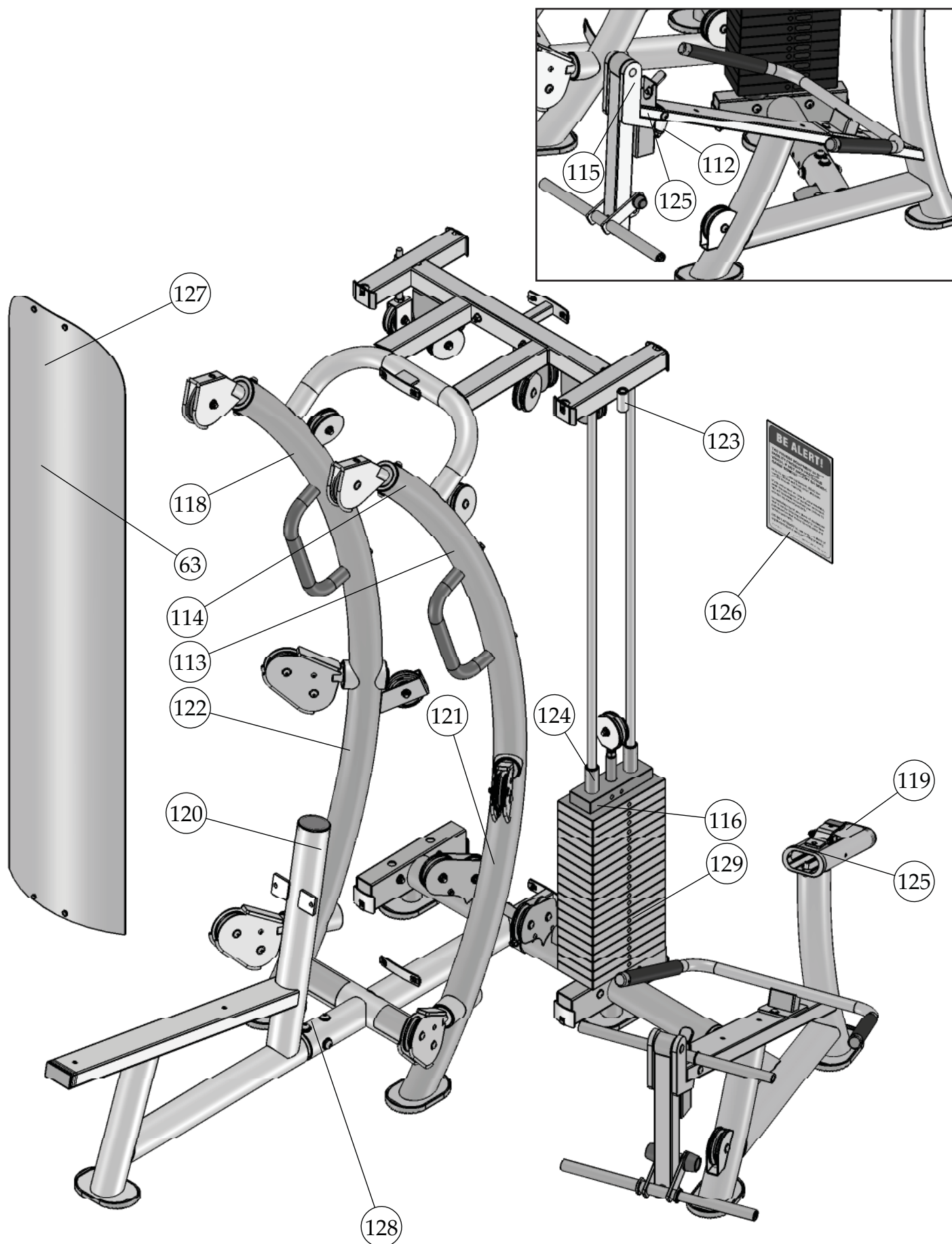

Carefully read ALL Danger, Warning & Caution labels posted on the machine

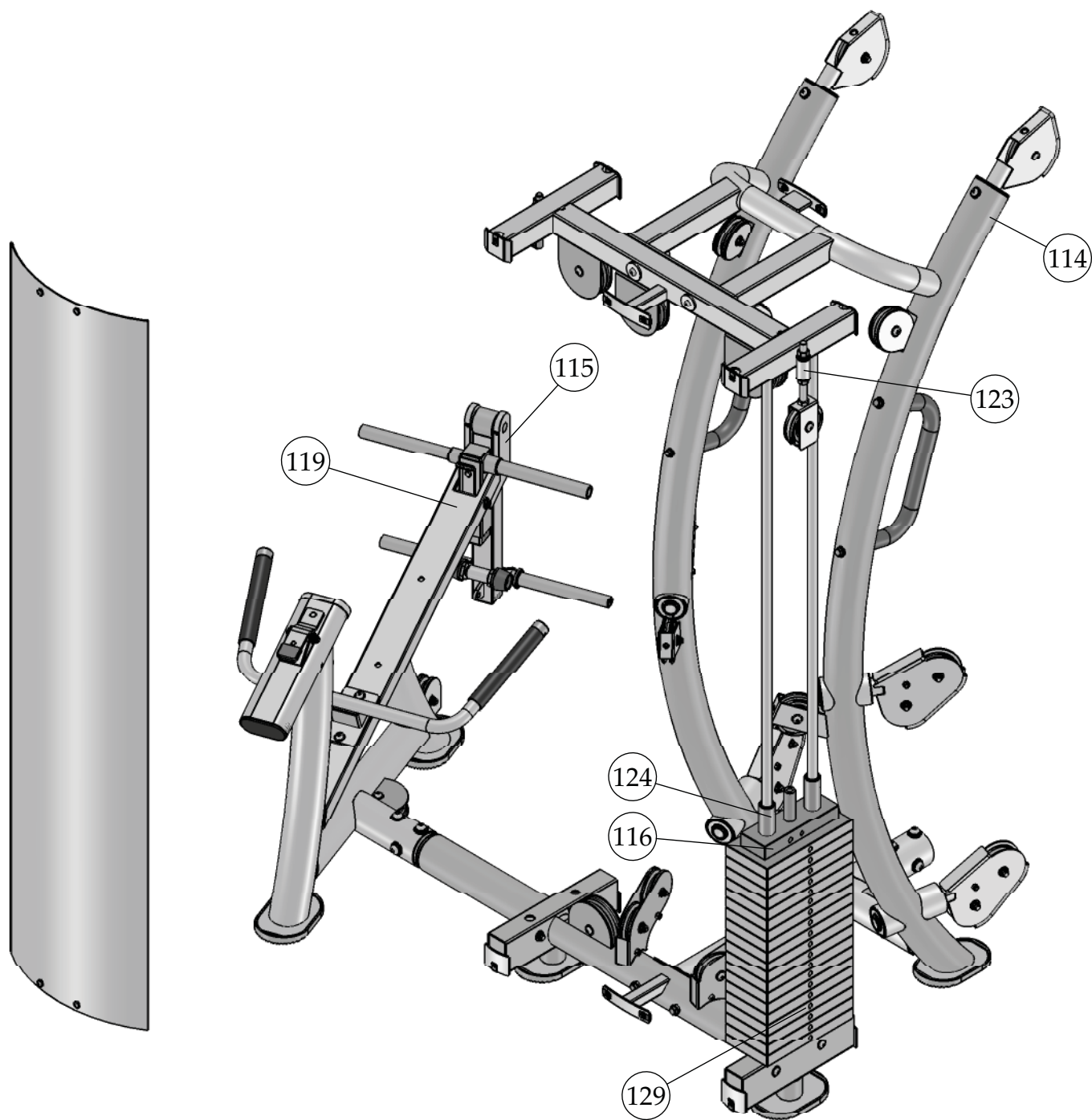

Carefully read ALL Danger, Warning & Caution labels posted on the machine

112



113



114

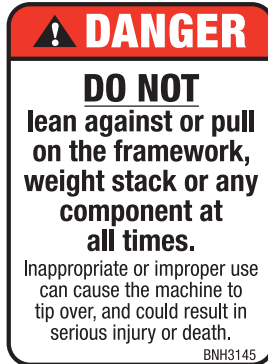

115



116



118

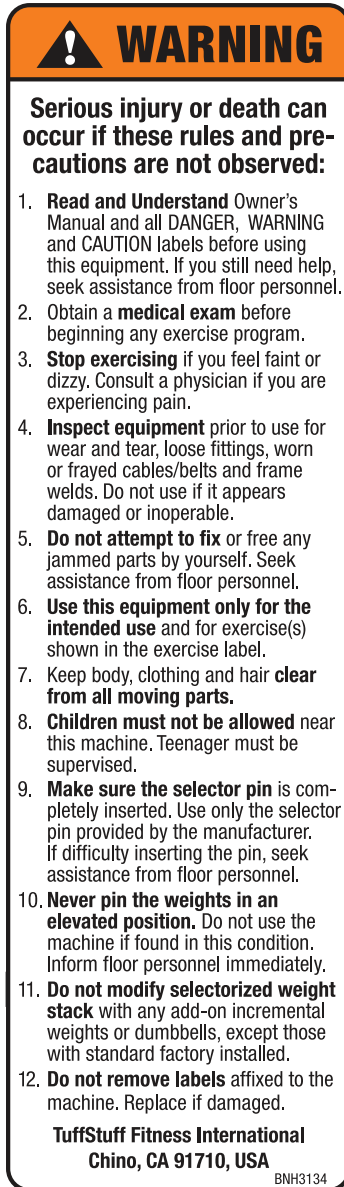

129

TOP PLATE 10 lbs.	TOP PLATE 4.5 kgs.
20 lbs.	9.0 kgs.
30 lbs.	13.6 kgs.
40 lbs.	18.1 kgs.
50 lbs.	22.7 kgs.
60 lbs.	29.5 kgs.
70 lbs.	31.8 kgs.
80 lbs.	36.3 kgs.
90 lbs.	40.8 kgs.
100 lbs.	45.4 kgs.
110 lbs.	49.9 kgs.
120 lbs.	54.4 kgs.
130 lbs.	59.0 kgs.
140 lbs.	63.5 kgs.
150 lbs.	68.0 kgs.
160 lbs.	72.6 kgs.
170 lbs.	77.1 kgs.
180 lbs.	81.6 kgs.
190 lbs.	86.2 kgs.
200 lbs.	90.7 kgs.

119



127



63

WARNING Important Safety Instructions: Before using this equipment, read and understand the Owner's Manual and all DANGER, WARNING and CAUTION labels affixed on the machine. Use this equipment only for its intended use. Make sure the selector pin is fully inserted in the hole and never pin the weight plates in an elevated position. Do not attempt to fix or free any jammed parts by yourself. Inform floor personnel immediately. Serious injuries or death can occur if these safety rules and precautions are not observed. Obtain a medical exam before beginning any exercise program. Stop exercising if you feel faint, dizzy or pain. Consult a physician immediately. www.tuffstufffitness.com

BASIC EXERCISE GUIDE

TUFFSTUFF FITNESS INTERNATIONAL INC., 13971 Norton Avenue, Chino, CA 91710, USA. BNH2909

128



Carefully read ALL Danger, Warning & Caution labels posted on the machine

124

IMPORTANT

For smooth performance, clean guide rods with Super Lube® spray lubricant and lubricate with Super Lube® (PTFE) grease. BNH2925

125

IMPORTANT

For smooth performance, lubricate all gliding surfaces with silicone spray lubricant. BNH2916

123

IMPORTANT

ADJUST
Cable Tension Here
BNH2924

120

WARRANTY

LIGHT COMMERCIAL

TEN (10) YEARS:

- Frames, welds, cams and weight plates

FIVE (5) YEARS:

- Pivot bearings, pulleys, bushings, gas shocks and guide rods

ONE (1) YEAR:

- Belts, linear bearings and pull-pin components

ALL OTHER PARTS not mentioned, one year from the date of delivery to the original purchaser.

SIX (6) MONTHS:

- Upholstery, cables, finish and rubber grips

Light Commercial Use:
Light Commercial warranty applies only to facilities like hotels, apartment complexes, personal training studios, fire & police stations, etc. where the equipment would be used by no more than 30 people per day. Refer to the Owner's Manual for details, assembly & maintenance requirements, review and understand all danger, warning and caution labels.

All warranty periods begin to run from the date of delivery to the original purchaser. The obligation of TuffStuff under this warranty is limited to repairing or replacing warranted defective parts, as TuffStuff may elect, at TuffStuff's facility in Chino, California, without charge to the Purchaser for either parts or labor. Purchaser is responsible for installation of repaired or replaced parts, and all transportation and insurance costs to and from TuffStuff's facility in Chino. For a detailed copy of the warranty, please contact:

TuffStuff Fitness International
Chino, CA 91710, USA
www.tuffstufffitness.com
BNH3136

121

INSPECTIONS

Recommended Inspection	DAILY	WEEKLY	MONTHLY	6-MONTH	YEARLY
Replace all parts at first signs of wear or damage.					
INSPECT: Links, pull-pins, snap locks, swivels, connectors, selector pin, and welded-joints.	X				
CLEAN: Upholstery with lanolin-base cleaner. Do not use Windex.	X				
INSPECT: Cables, Belts and tension (adjust if needed).	X				
INSPECT: All labels		X			
INSPECT: All nuts and bolts (tighten if needed).		X			
INSPECT: Accessory bars, handles, rubber grips.		X			
INSPECT: All anti-skid surfaces.		X			
CLEAN & LUBRICATE: Clean guide rods with Super Lube® spray lubricant and lubricate with Super Lube® (PTFE) grease.			X		
LUBRICATE: Seat sleeves, pull-pin sliding mechanism, bushings and linear bearings.			X		
CLEAN & WAX: All powder-coat finishes.				X	
REPLACE: Cables & connecting parts.					X

Use only genuine TuffStuff replacement parts. Failure to do so will void warranty and could result in serious injury or death.

TuffStuff Fitness International
Chino, CA 91710, USA
www.tuffstufffitness.com BNH3137

122

SCHEDULE
Replacement Parts

Recommended TuffStuff Parts (replace or as needed)	9-MONTH	12-MONTH	15-MONTH	18-MONTH
Upholstery	X			
Foam Rolls	X			
Cables		X		
Rubber Grips		X		
Nylon Handles			X	
Pull-Pins			X	
Plastic Guides			X	
Weight Selector Pin			X	
Abdominal Strap			X	
Adj. Release Handle				X
Black Caster Wheels				X
Buckle Seat/Belt				X
Labels (as needed)				

Use only TuffStuff replacement parts when servicing. Failure to do so will void warranty on product and could result in personal injury.

TuffStuff Fitness International
13971 Norton Avenue
Chino, CA 91710
BNH3135

126

BE ALERT!

THE FITNESS EQUIPMENT IN THIS FACILITY PRESENTS HAZARDS WHICH, IF NOT AVOIDED, COULD CAUSE SERIOUS INJURY OR DEATH.

Prior to using the equipment, READ the warning labels and instruction placards affixed to each machine.

If you are unsure on how to use a machine, seek the assistance of our floor personnel. We will be happy to instruct you on how to use the equipment properly.

Immediately report any piece of equipment that is not functioning properly to our floor personnel so that it may be evaluated and service promptly.

DO NOT ATTEMPT to use or fix any piece of equipment that is not functioning properly.

ASTM F1749-96 TUFFSTUFF FITNESS INTERNATIONAL, CHINO, CA 91710
BNH3138

It is extremely important that the **Facility Sign** shown to the left be installed in plain view of the unit.

You should have received it along with this Owner's Manual. If you did not receive this Facility Sign with your order, you can obtain one at no cost to you from TuffStuff Fitness by contacting our service department at:

1 (888) 884-8275
service@tuffstuff.net
service1@tuffstuff.net

Important Safety Instructions



It is the responsibility of the facility owner and/or owner of the equipment to review the Owner's Manual with their facility personnel and understand all Danger, Warning and Caution labels affixed on the machine. It is the responsibility of the floor personnel to instruct users on proper operation of the equipment and review all danger, warning and caution labels.

⚠ WARNING SERIOUS INJURY OR DEATH CAN OCCUR IF THESE SAFETY PRECAUTIONS ARE NOT OBSERVED:

1. Obtain a medical exam before beginning any exercise program.
2. Read and understand Owner's Manual and all **Danger, Warning and Caution** labels before using this equipment. If you still need help, seek assistance from floor personnel.
3. **Inspect the equipment** before each use for wear and tear, loose fittings, worn or frayed cables and frame welds. **DO NOT USE** if it appears to be inoperable or damaged.
4. Stop exercising if you feel faint or dizzy. Consult a physician if you are experiencing pain.
5. **Use this equipment only for the intended use and for exercise(s) shown on page 34-37.**
6. Keep body, clothing and hair clear from all moving parts. Do not attempt to free any jammed parts by yourself.
7. Always warm-up before and cool-down after weight training. Warm-up for 10-15 minutes with stretching and cardiovascular exercises. Cool-down should include light stretching exercises for 5-15 minutes.
8. Never hold your breath – will limit the flow of oxygen to your brain and may cause dizziness. The most often used breathing pattern is inhaling during least resistance and exhaling during maximum resistance.
9. Do not use accessories or accessory attachments that are not recommended by TFI.
10. Make sure selector pin is completely inserted. Use only the selector pin provided by the manufacturer.
11. Never pin the weights in an elevated position. Do not use the machine if found in this condition.
4. Provide an adequate safety perimeter between the machine, walls and other equipment to ensure that the facility has proper clearance for usage and training.
5. Post and disclose all safety, rules and regulations on a bulletin board easily accessible to users.
6. Perform regular maintenance (see Inspection Label). Pay special attention to areas most susceptible to wear and tear, including but not limited to cables, pulleys and rubber grips.
7. **Do not** lean against or pull on the framework, weight stack or any component at all times.
8. **Children must not** be allowed near the equipment. Teenager must be supervised.
9. Replace immediately all parts at first sign of wear or damage. If unable to replace worn or damaged components/parts, remove machine from service until the repair is made.
10. Use only genuine TuffStuff replacement parts. Failure to do so will void warranty and could result in serious injury or death to the users.
11. **Do not remove** any decals affixed to the machine. Replace if damaged.
12. **Do not alter or modify** the original manufacturer's weight stack with any add-on incremental weights, weight plates or dumbbells except those with standard factory installed option.
13. Maintain a service contract with a TFI Authorized Dealer or a Professional Service Company approved by TFI. Keep a service log of all maintenance and repair activities. **NOTICE:** It is the sole responsibility of the owner or facility operator to ensure that regular maintenance is performed.

Facility Safety Guidelines and Practices

1. Read and understand the Owner's Manual before assembling, servicing or using the equipment.
2. Equipment to be installed by TFI Authorized Dealer or Professional Service Company approved by TFI.
3. Make sure each machine is set up and operated on a solid level surface. Do not install equipment on an uneven surface.



DANGER: indicates an imminently hazardous situation which, if not avoided, will result in death or serious injury.



WARNING: indicates a potentially hazardous situation which, if not avoided, will result in death or serious injury.



CAUTION: indicates a hazardous situation which, if not avoided, could result in minor or moderate injury.

Registration, Service & Assembly



Thank you for purchasing the HTX-2000 Dual Stack-Functional Trainer Weight Stack. This machine is part of the TuffStuff line of quality strength training equipment. To maximize your use of the equipment, please study the Owner's Manual thoroughly.

Registration

To avoid unnecessary delays on warranty parts and to insure that a permanent record of your purchase is on file with our company, be sure to register online at <http://www.tuffstufffitness.com> or mail to address shown below within 10 days of purchase.

Obtaining Service

Please use this Owner's Manual as your guide to all parts included in your shipment. When ordering parts, you must specify the part number and description from this owner's manual. **Use only genuine TuffStuff replacement parts when servicing the equipment.** Failure to do so will void warranty and could result in serious injury or death.

For information about product operation or service:

Phone: 909-629-1600 Toll Free 888-884-8275
Fax: 909-629-4967
E-mail: service@tuffstuff.net or service1@tuffstuff.net
Hours: M-F 8:00 – 4:30 PST
Or write to: TuffStuff Fitness International Inc.
Customer Service
13971 Norton Avenue, Chino, CA 91710

Retain this Owner's Manual for future reference when ordering service or parts. To assist you better, please be prepared to provide the following information:

1. Model Number
2. Place of Purchase
3. Serial Number
4. Part # and Description

Required Tools

The basic tools that you will need to assemble the HTX-2000 but are not limited to:

- 9/16", 3/4", 1/2" combination wrenches
- Adjustable wrench
- Ratchet wrench with 9/16", 3/4", 1/2" sockets
- External retaining ring pliers
- Rubber mallet, measuring tape & utility knife
- Super Lube® spray lubricant and grease
- Windex or household glass cleaner

Assembly Requirements

Follow these installation requirements when assembling the HTX-2000. Use the overhead view on the Content Page to layout your floor plan before assembling.

Set up the HTX-2000 on a clean, solid, flat surface. A smooth, flat surface under the machine helps keep it level.

Allow ample space around the machine for safe unrestricted use and easier access.

Insert all bolts in the same direction. For aesthetic appearance, insert all bolts in the same direction unless specified (in text or illustration) to do otherwise.

Leave room for adjustments. Do not fully tighten fasteners until instructed in the assembly steps to do so (to prevent any difficulty with alignment of parts during the assembly process). When not instructed, tighten fasteners such as bolts, nuts and screws so the unit is stable, but leave room for adjustments.

Assembly Tips

Read all "Notes" on each page before beginning each step.

While you may be able to assemble the HTX-2000 using the illustrations only, IMPORTANT safety notes and other tips are included in the text.

Some pieces may have extra holes that you will not use. Use only those holes indicated in the instructions and illustration.

NOTE: With so many assembled parts, proper alignment and adjustment is critical. While tightening the nuts and bolts, be sure to leave room for final adjustments.

CAUTION: Obtain assistance from TFI if you have difficulty assembling the HTX-2000. Please do not attempt to complete the assembly as this could result in equipment failure and serious injuries to the users.

Symbols & Description

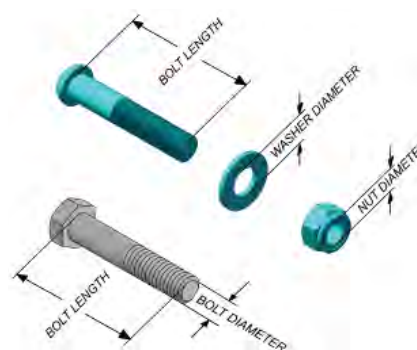

Loosely Tighten

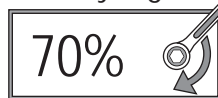

Loosely Tighten

Loosely tighten all hardware in this step. DO NOT Fully Tighten. Some component(s) may need pre-assembly and or alignment during the assembly process.

Fully Tighten



Fully Tighten

Wrench tighten all hardware in this step.

Inspection/Maintenance



Perform regular maintenance (see Inspection Label). Pay special attention to areas most susceptible to wear and tear, including but not limited to cables, pulleys and rubber grip. TFI recommends you maintain a service contract with a TFI Authorized Dealer or a Professional Service Company approved by TFI. Keep a service log of all maintenance and repair activities. Extra copies can be downloaded from our website www.tuffstufffitness.com

INSPECTIONS

Recommended Inspection

Replace all parts at first signs of wear or damage.

	DAILY	WEEKLY	MONTHLY	6-MONTH	YEARLY
INSPECT: Links, pull-pins, snap locks, swivels, connectors, selector pin, and welded-joints.	X				
CLEAN: Upholstery with lanolin-base cleaner. Do not use Windex.	X				
INSPECT: Cables, Belts and tension (adjust if needed).	X				
INSPECT: All labels		X			
INSPECT: All nuts and bolts (tighten if needed).		X			
INSPECT: Accessory bars, handles, rubber grips.		X			
INSPECT: All anti-skid surfaces.		X			
CLEAN & LUBRICATE: Clean guide rods with Super Lube® spray lubricant and lubricate with Super Lube® (PTFE) grease.			X		
LUBRICATE: Seat sleeves, pull-pin sliding mechanism, bushings and linear bearings.			X		
CLEAN & WAX: All powder-coat finishes.				X	
REPLACE: Cables & connecting parts.					X

Use only genuine TuffStuff replacement parts. Failure to do so will void warranty and could result in serious injury or death.

TuffStuff Fitness International
Chino, CA 91710, USA
www.tuffstufffitness.com BNH3137

INSPECTION / MAINTENANCE RECORDS

DATE	REPLACEMENT	REPAIRS	INSPECTED BY

WARRANTY REPAIRS

DATE	REPLACEMENT	REPAIRS	INSPECTED BY



WARNING:

THE FOLLOWING CONDITIONS MAY INDICATE A WORN CABLE. REPLACE IMMEDIATELY.



"NECKING", STRECHED CABLE COVERING



A CRACK IN THE CABLE COVER



A TEAR IN THE CABLE COVER



A BREAK ON THE CABLE



CABLE END SLIPPING OUT

IMPORTANT NOTE:

DAMAGED OR WORN CABLE (AS SHOWN ABOVE) MAY DAMAGE THE PULLEY(S). YOU MUST INSPECT THE PULLEYS AT THIS TIME FOR WEAR AND TEAR. REPLACE IF NEEDED.

Step 1



NOTE:

1. IT IS STRONGLY RECOMMENDED THAT TWO PEOPLE PARTICIPATE IN THE ASSEMBLY OF THIS UNIT.

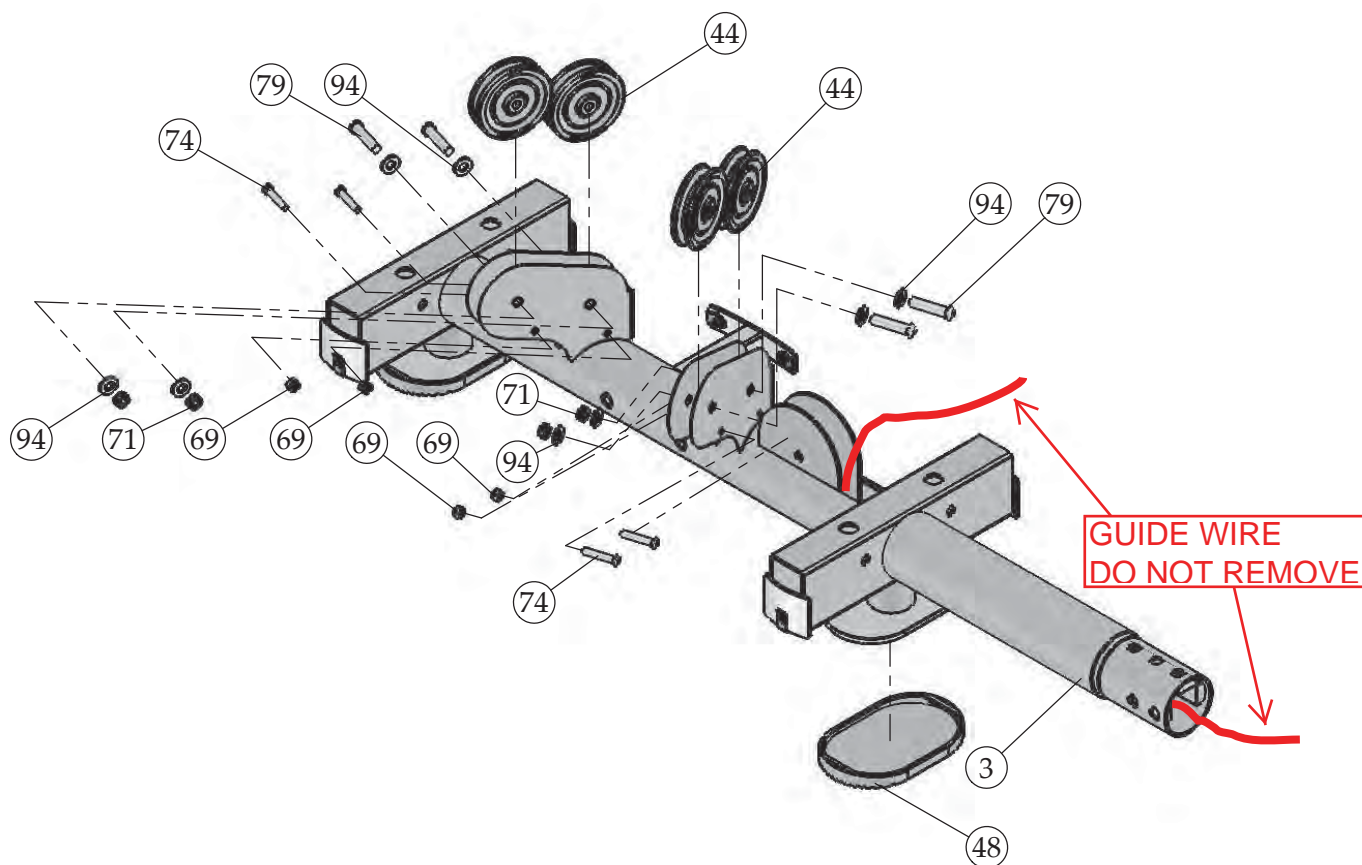

DO NOT REMOVE GUIDE WIRE AS IT WILL BE USED ON STEP 15.

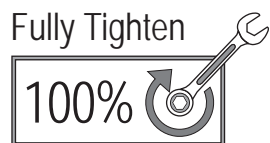

Fully Tighten

Wrench tighten all hardware in this step.

Step 2

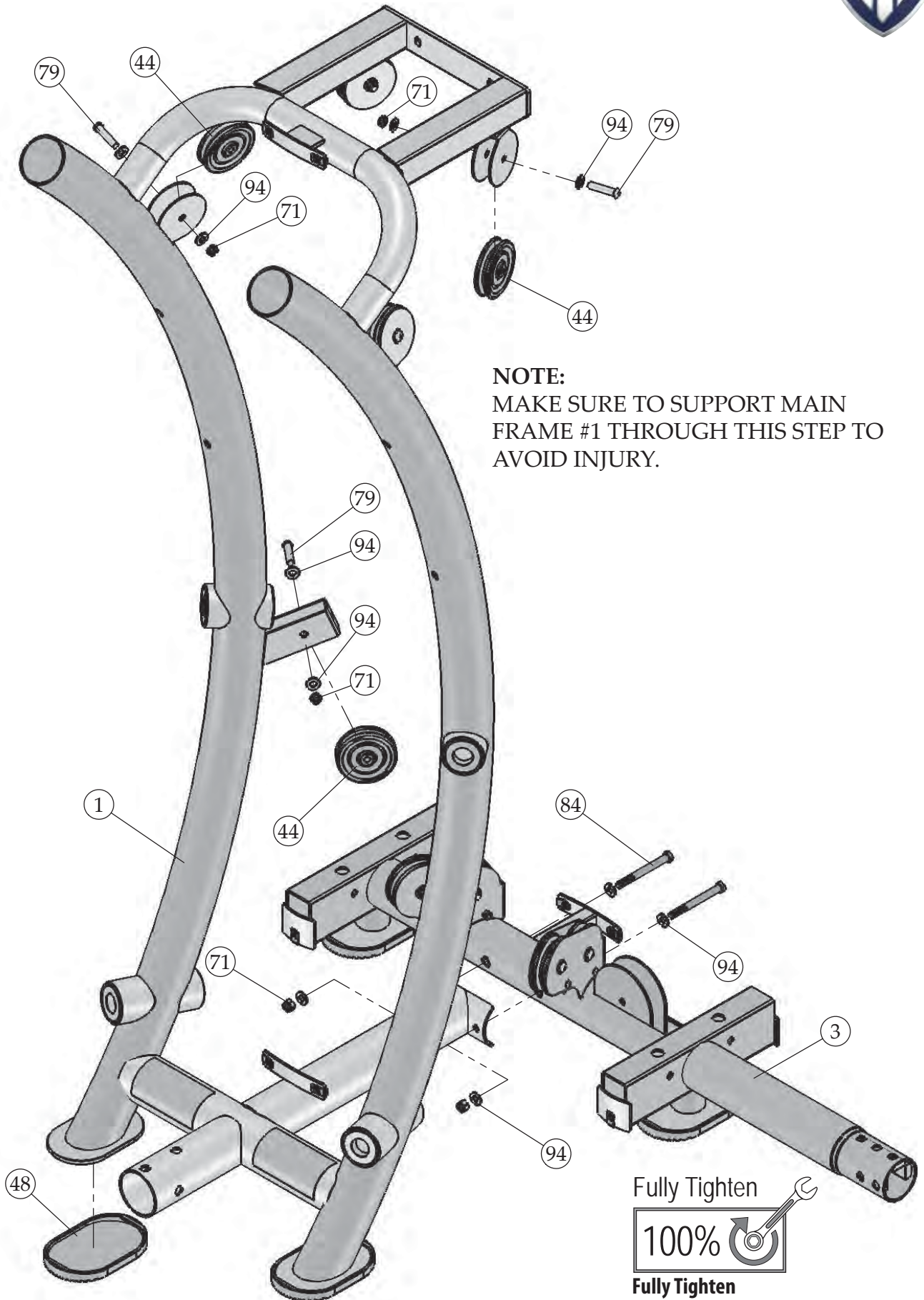

NOTE:
MAKE SURE TO SUPPORT MAIN
FRAME #1 THROUGH THIS STEP TO
AVOID INJURY.

Fully Tighten
100% 
Fully Tighten
Wrench tighten all hardware in this step.

Step 3

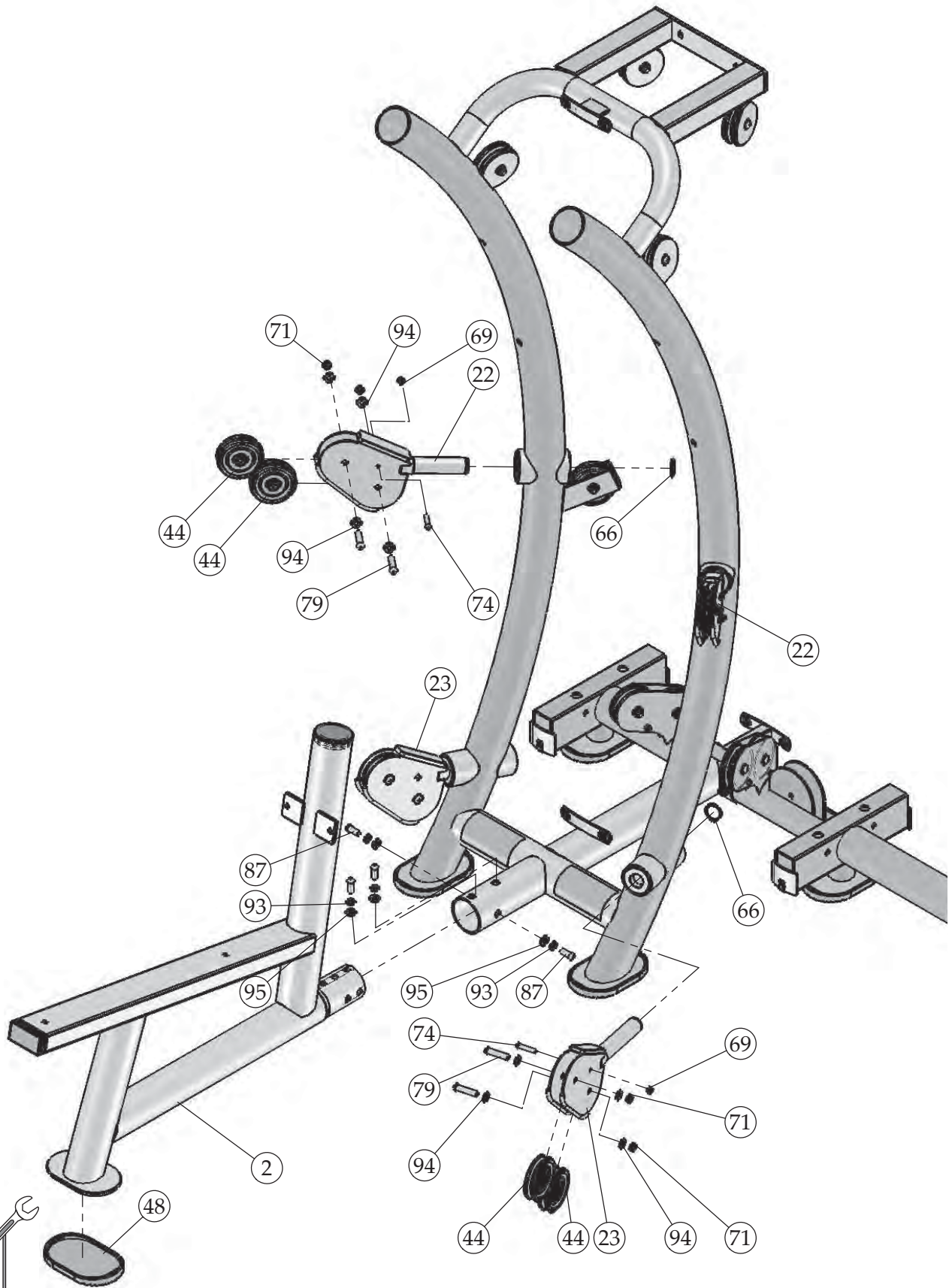

Fully Tighten



Fully Tighten

Wrench tighten all hardware in this step.

Step 4



NOTE:

1. CONNECT BOTH WIRES BEFORE ASSEMBLING ITEM NO 4. AND LEAVE IN PLACE AS IT WILL BE USED ON STEP 15.

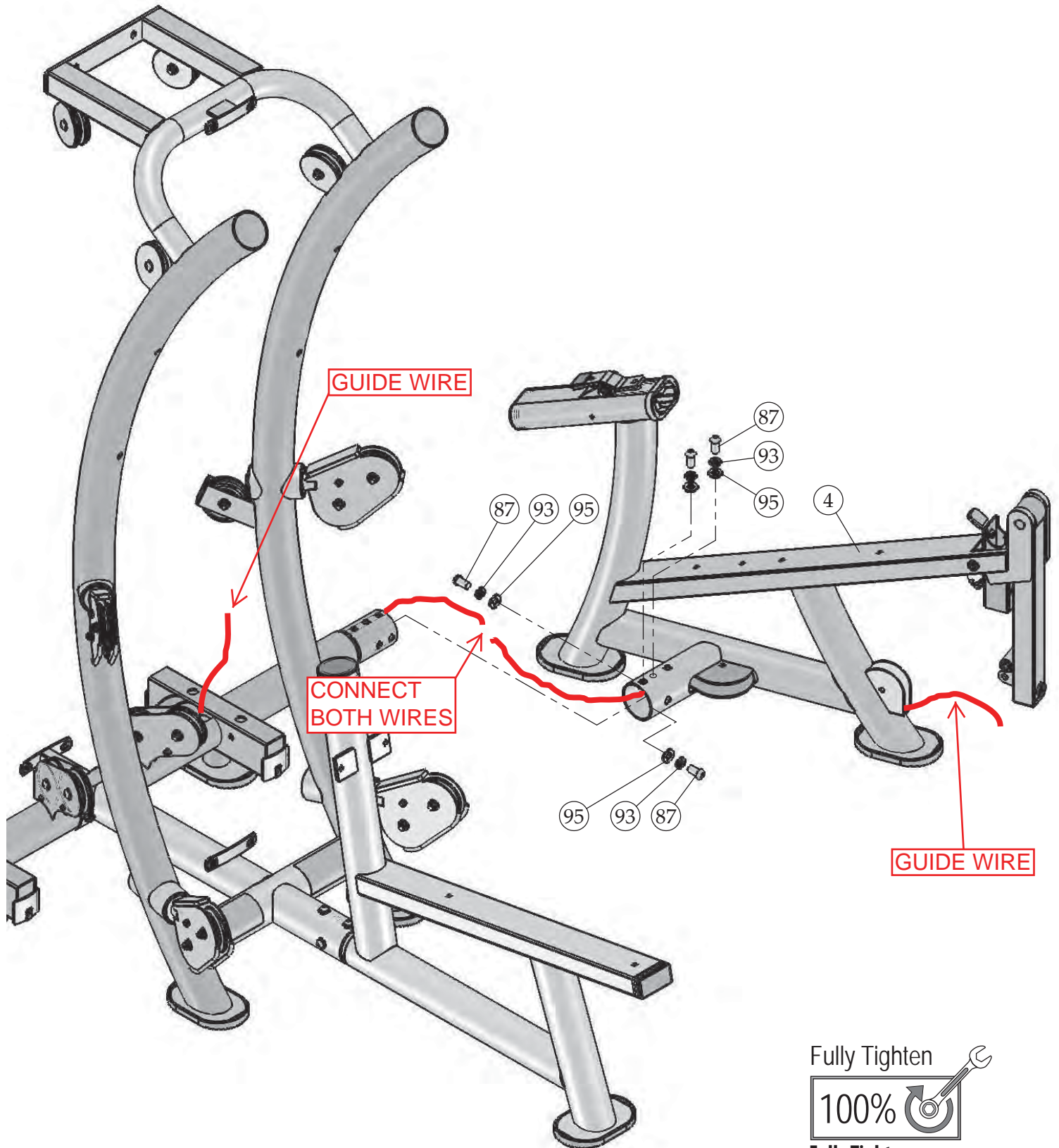

Fully Tighten



Fully Tighten

Wrench tighten all hardware in this step.

Step 5

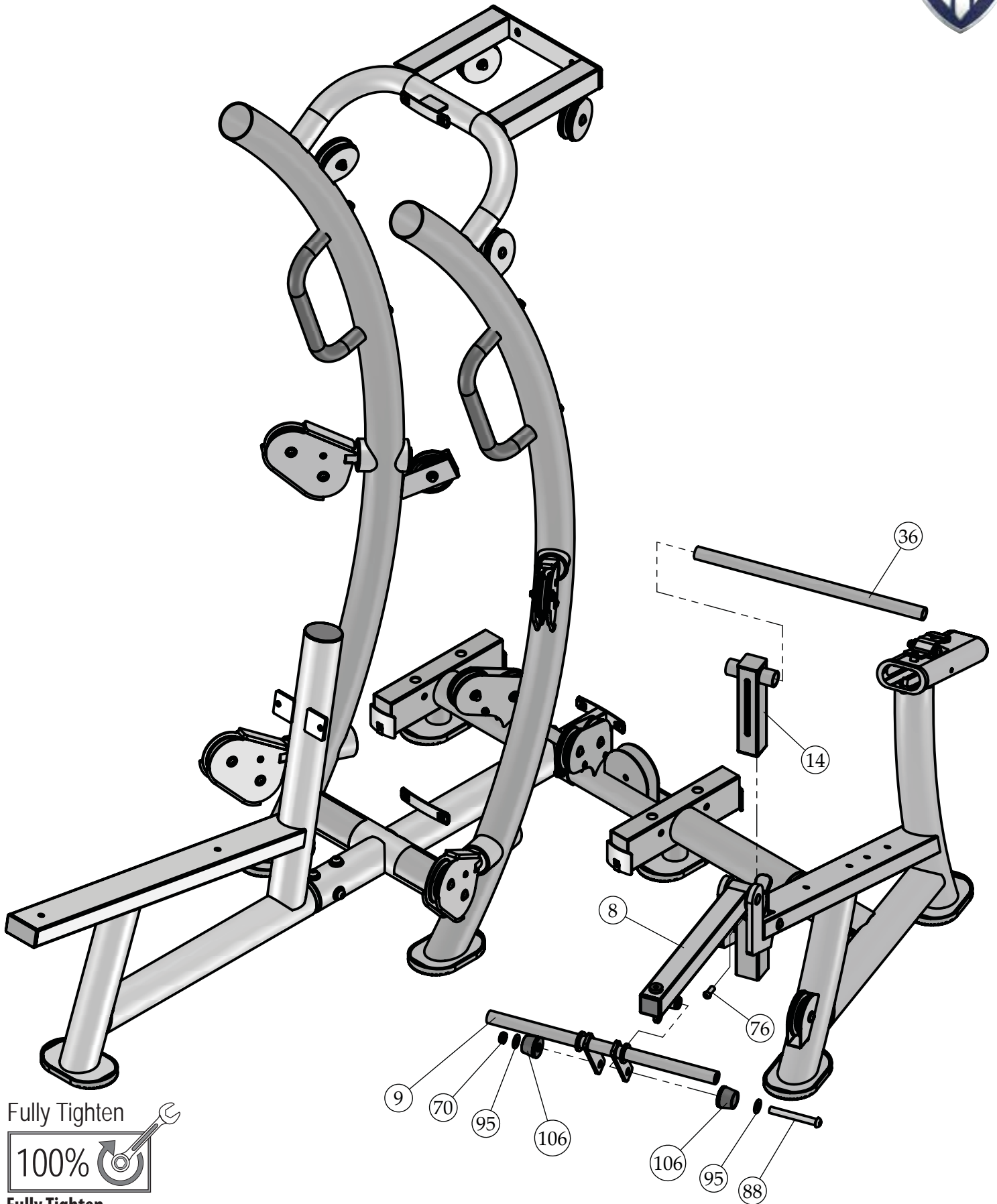

Fully Tighten
100%

Fully Tighten
Wrench tighten all hardware in this step.

Step 6

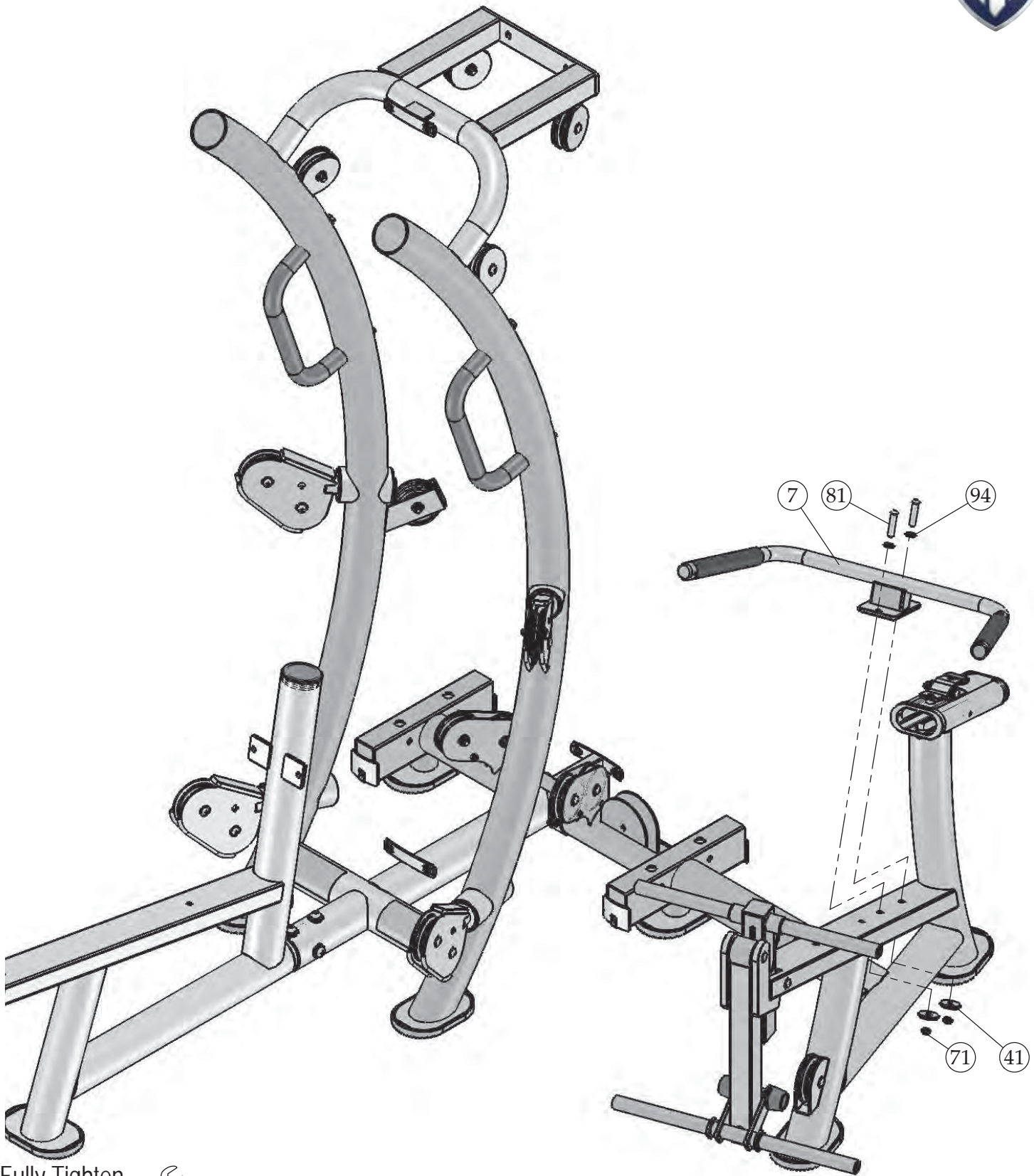

Fully Tighten



Fully Tighten

Wrench tighten all hardware in this step.

HTX-2000 Dual Stack-Funtional Trainer

www.tuffstufffitness.com

Step 7

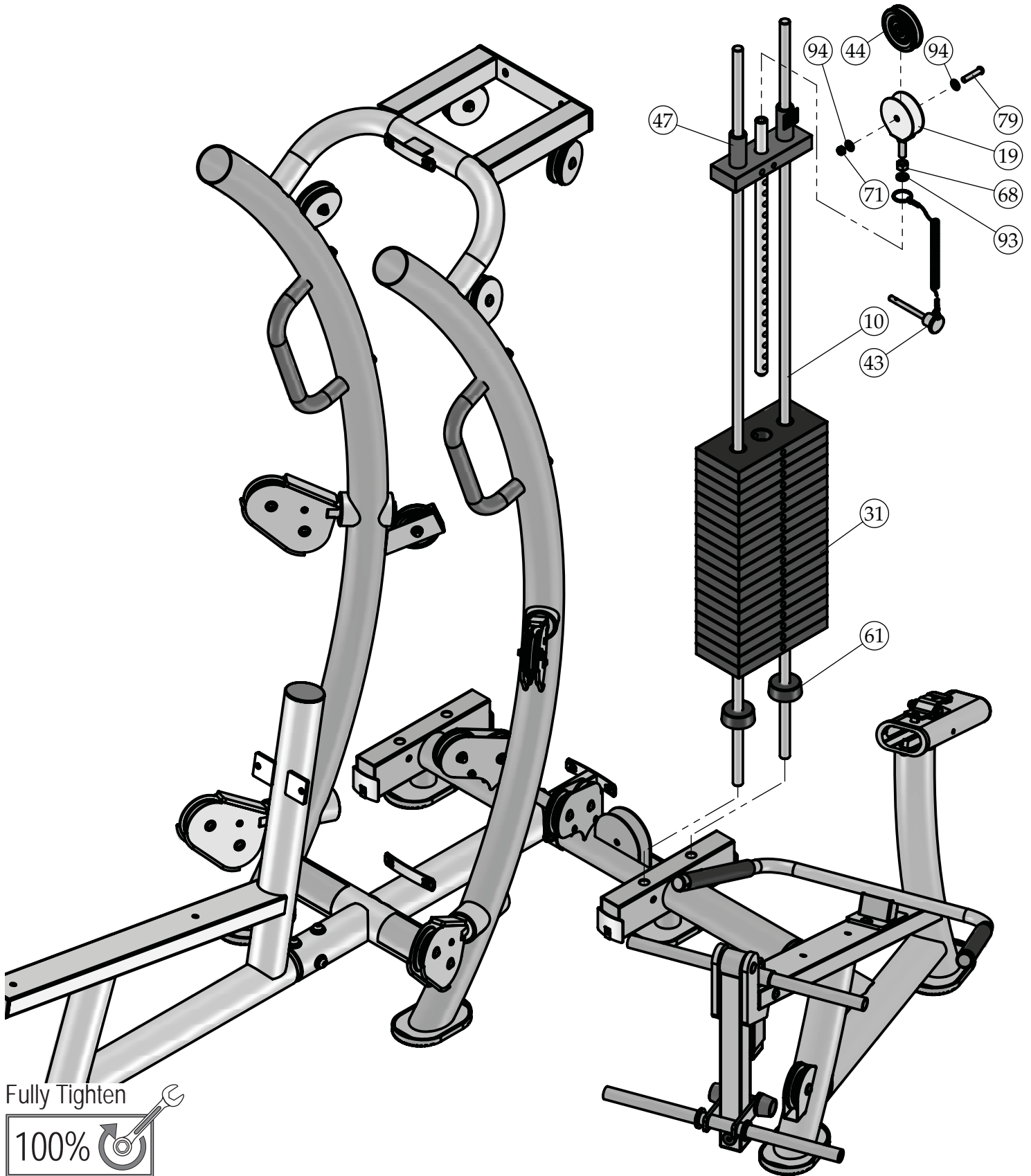

Fully Tighten
100%

Fully Tighten
Wrench tighten all hardware in this step.

Step 8

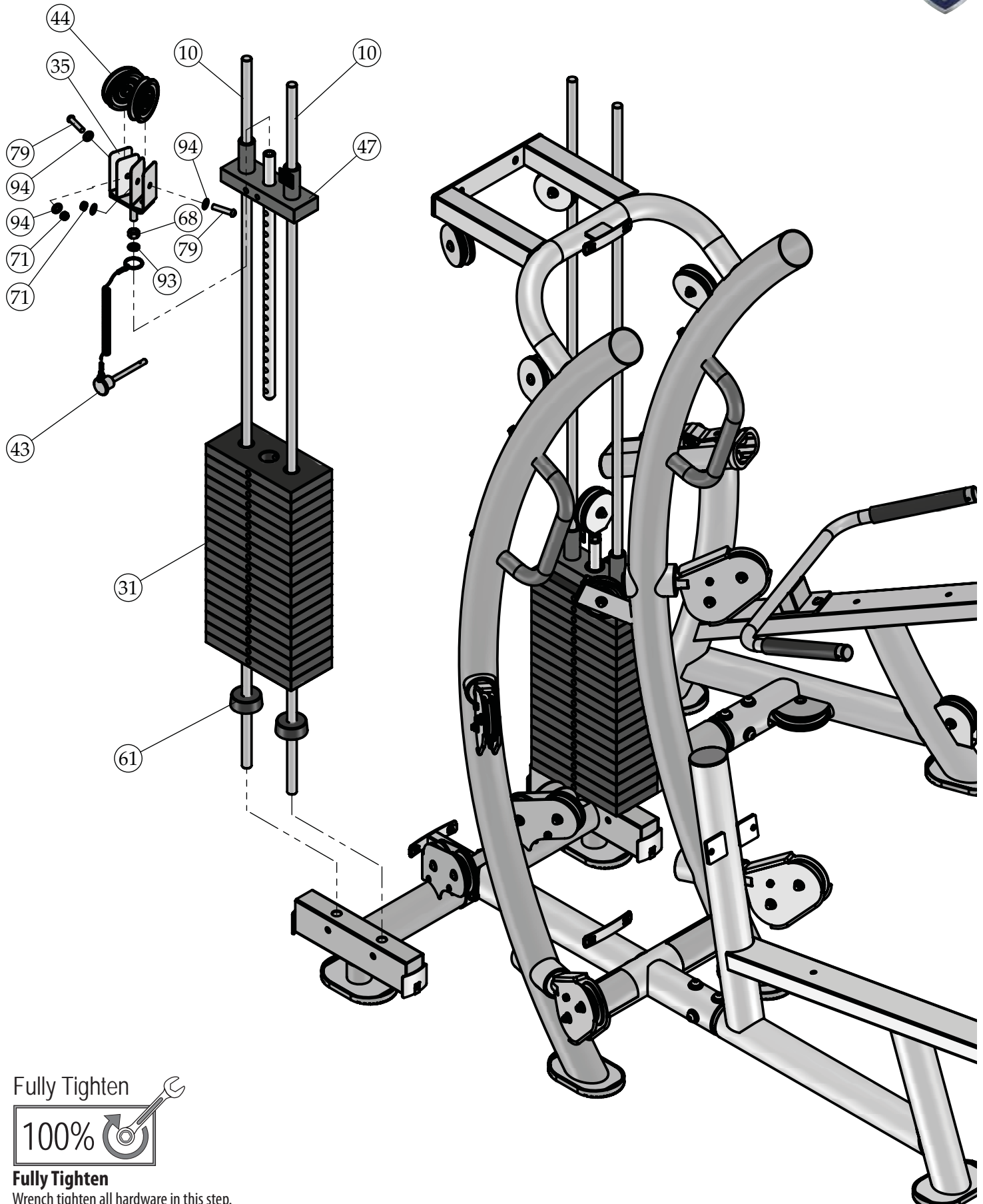

Fully Tighten



Fully Tighten

Wrench tighten all hardware in this step.

Step 9



NOTE:

1. LOOSLY TIGHTEN SOCKET CAP SCREW GR-8 Z/P 3/8-16 X 3 (#85) UNTIL AFTER COMPLETING STEP 10.

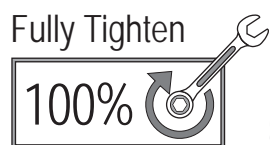
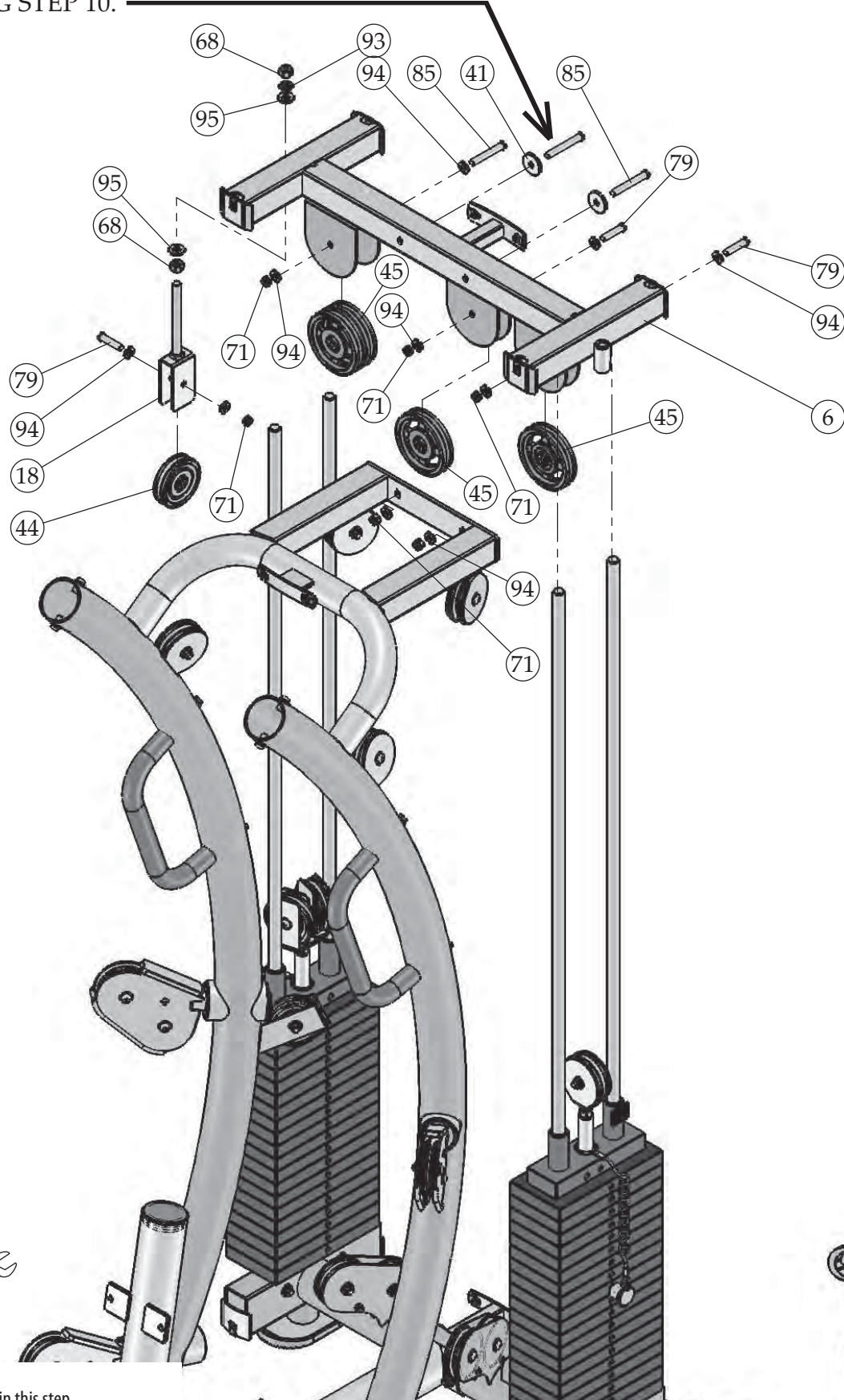

Fully Tighten
Wrench tighten all hardware in this step.

Step 10



NOTES:

1. REPEAT ASSEMBLY STEP ON OTHER WEIGHT STACK.
2. ONCE GUIDE RODS ARE SECURED ON BOTH WEIGHT STACKS, TIGHTEN SCREWS (#85) FROM PREVIOUS STEP.

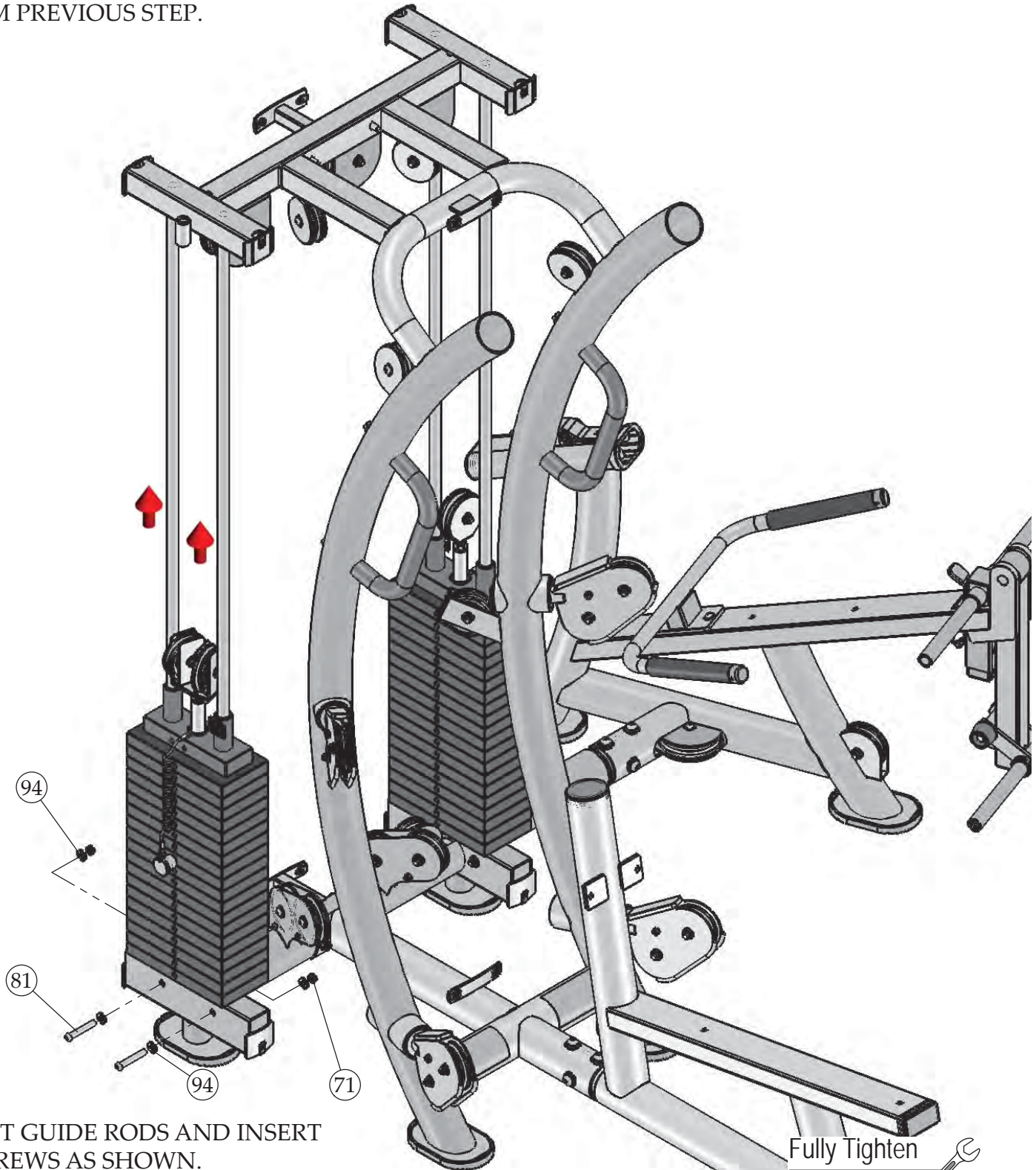

LIFT GUIDE RODS AND INSERT SCREWS AS SHOWN.

Fully Tighten



Fully Tighten

Wrench tighten all hardware in this step.

Step 11



NOTE:

1. TOP PLATE LABEL GOES ON HOLE OFF CENTER AS SHOWN. LABEL WILL COVER HOLE ON CENTER.
2. FOLLOW THESE INSTRUCTIONS FOR BOTH WEIGHT STACKS.

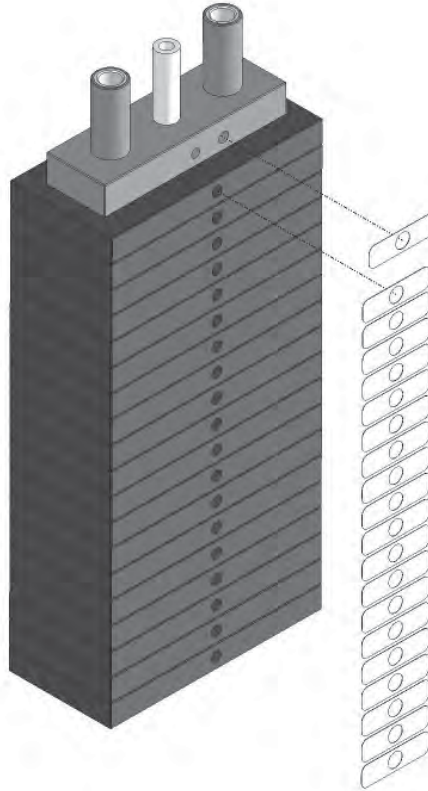

Weight stack label and lubrication instructions

1. Wipe front surface of weight stack with rubbing alcohol and wipe dry.
2. Peel off back sheet (adhesive side) from label #129 and make sure that the labels remain attached to the application tape.
3. Line up hole on the second label to hole on the first weight plate.
4. Make sure the hole on the last label lines up with last weight plate and slowly press into place.
5. Gently remove application tape and rub each label firmly against the weight stack.
6. Once this is complete, repeat this procedure for top plate label.
6. Allow labels to stand for 2 days to allow adhesive to cure fully.
7. Open the lube package provided and apply a thin film of lubricant around the first 3 inches of the guide rods above the top plate.
8. After the cables are installed, do a set of reps to spread the lubricant thoroughly.



Step 12 Lat Cable Routing

NOTE:

1. SOME PARTS CUT OUT/NOT SHOWN FOR CLARITY.
2. MAKE SURE TO TIGHTEN SCREW ITEM NO. 91

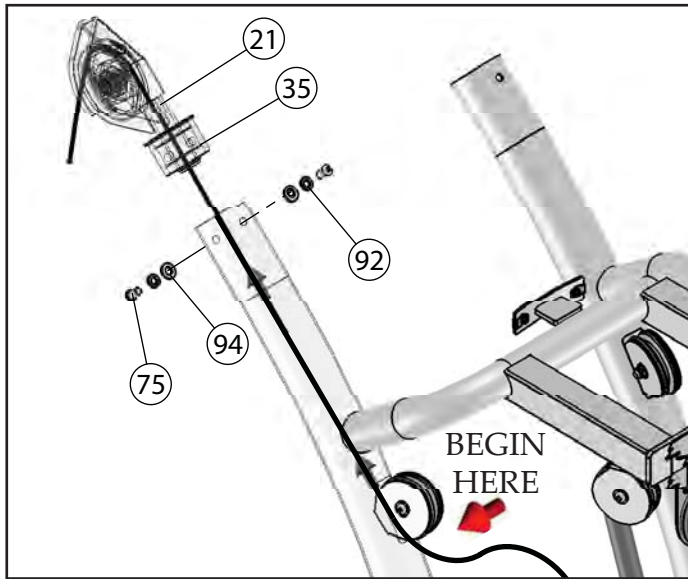

BEGIN BY RUNNING CABLE INSIDE THE TUBE TO UPPER PULLEY AND ASSEMBLE TOP BEARING HOUSING (35) AS SHOWN.

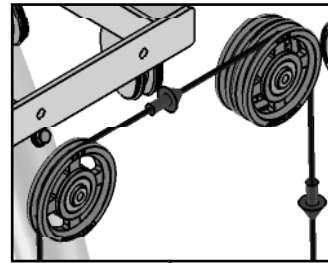

CONTINUE ON NEXT PAGE

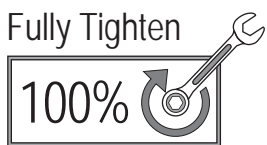
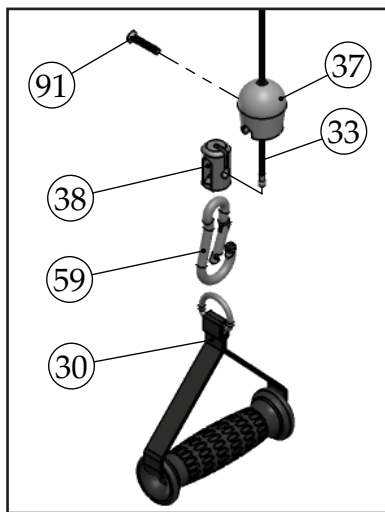

Fully Tighten

Wrench tighten all hardware in this step.

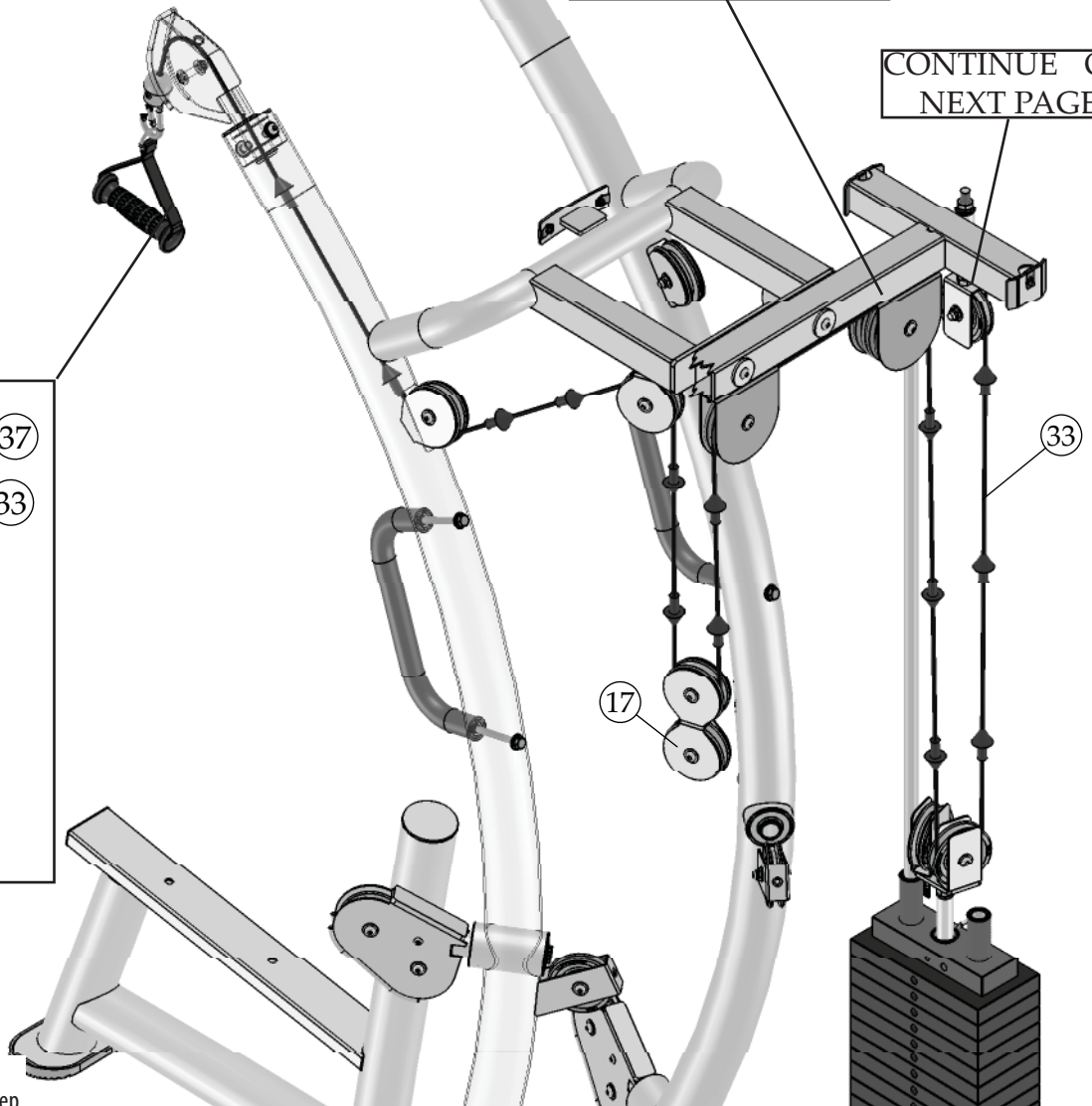

Continue Lat Cable Routing



NOTE:

1. SOME PARTS CUT OUT/NOT SHOWN FOR CLARITY.
2. MAKE SURE TO TIGHTEN SCREW ITEM NO. 91

CONTINUE FROM
PREVIOUS PAGE

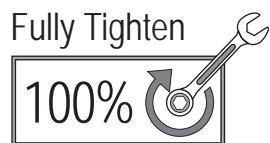
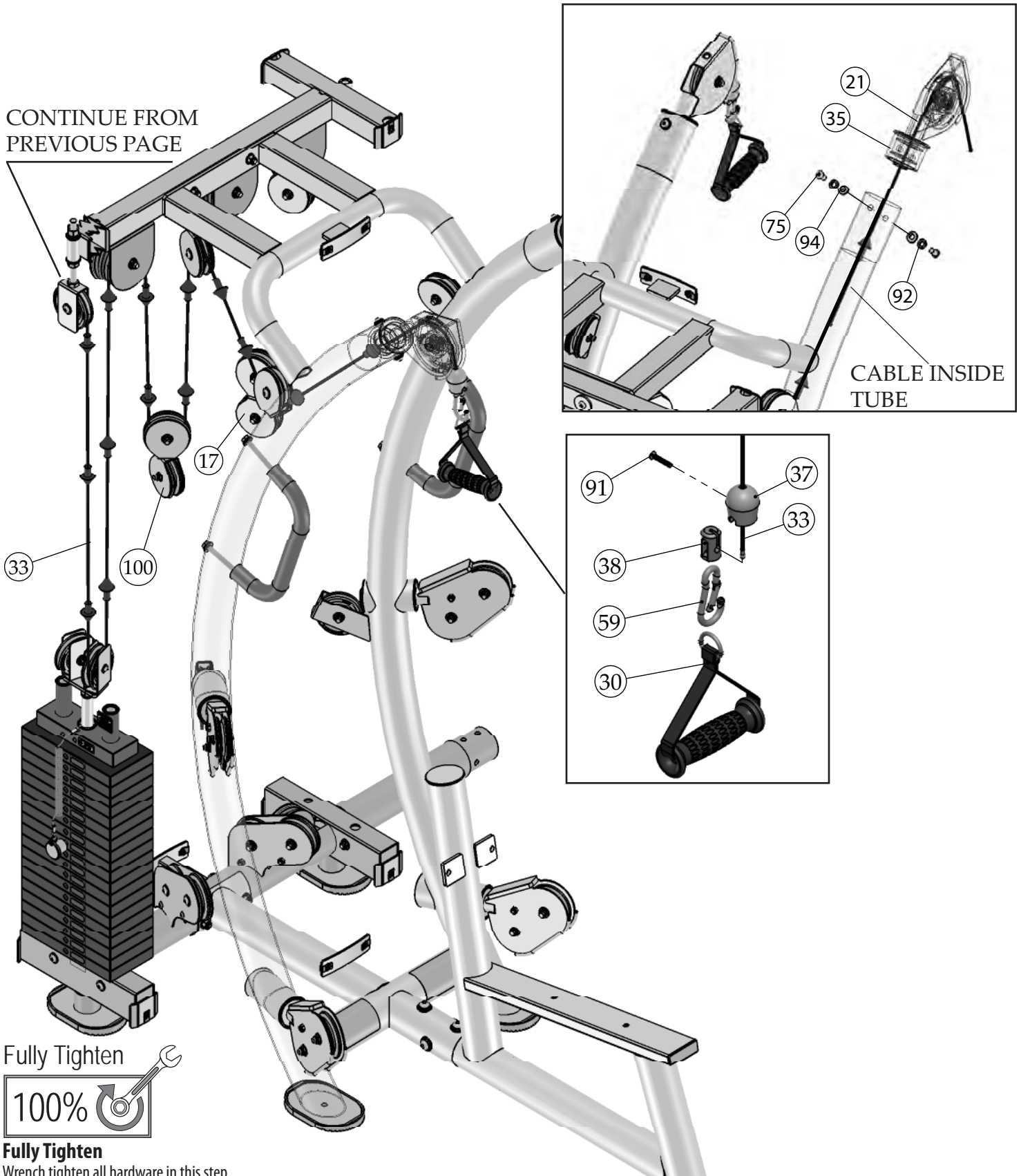

Fully Tighten
Wrench tighten all hardware in this step.

Step 13 Low Row Cable Routing



NOTE:

1. SOME PARTS CUT OUT/NOT SHOWN FOR CLARITY.
2. ONCE PULLEYS ARE IN PLACE, MAKE NECESSARY ADJUSTMENT TO THE CABLE ON THE ADJUSTABLE PULLEY BRACKET #18.
3. MAKE SURE TO TIGHTEN SCREW ITEM NO. 91

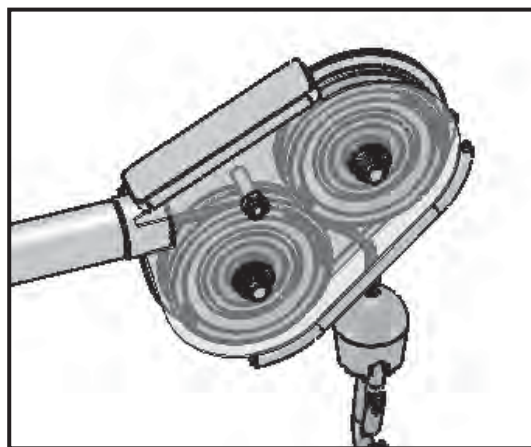
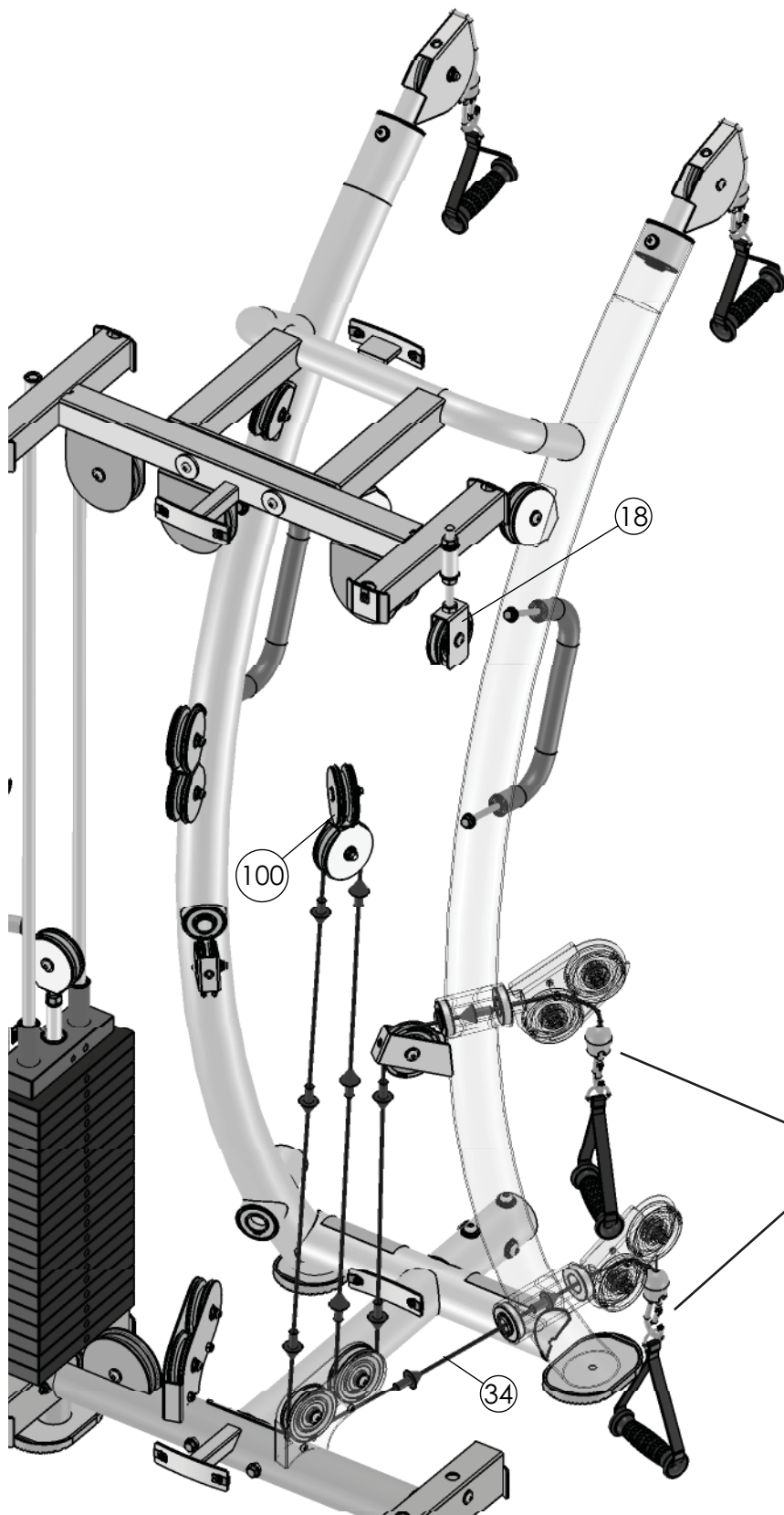

MAKE SURE CABLE RUNS UNDERNEATH SCREW #74 AS SHOWN ABOVE.

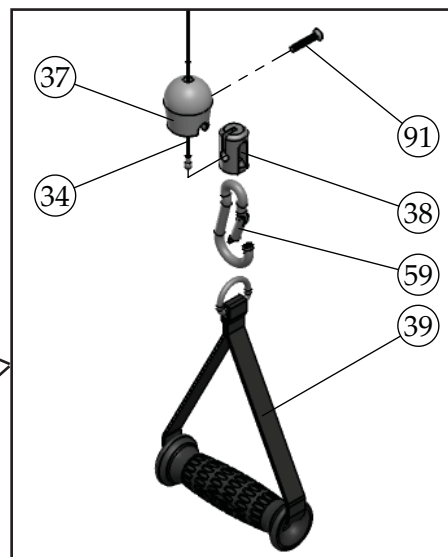

Fully Tighten



Fully Tighten

Wrench tighten all hardware in this step.



Step 14 Low Row Cable Routing

NOTE:

1. SOME PARTS CUT OUT/NOT SHOWN FOR CLARITY.
2. MAKE SURE TO TIGHTEN SCREW ITEM NO. 91

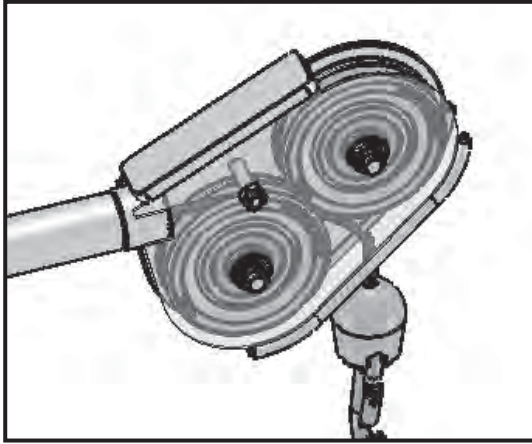

MAKE SURE CABLE RUNS UNDERNEATH SCREW #74 AS SHOWN ABOVE.

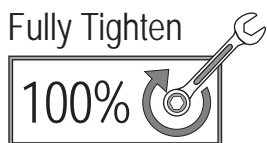
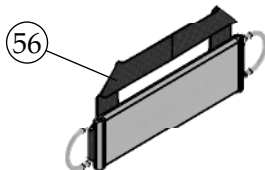
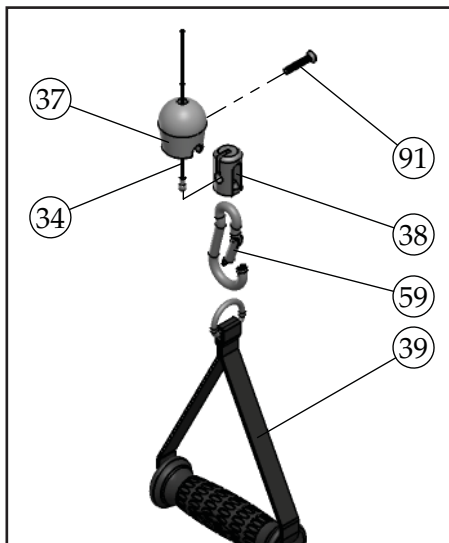
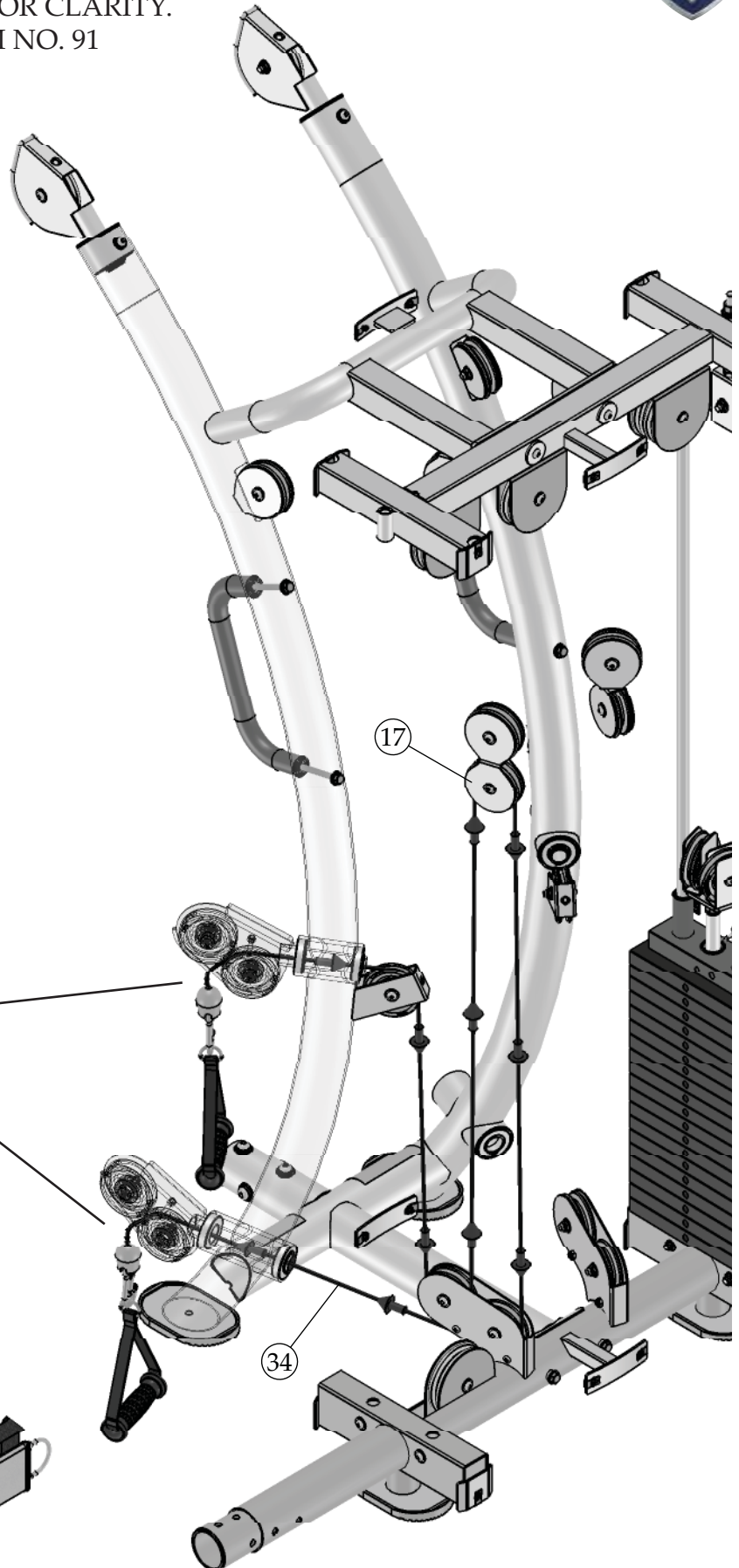

Fully Tighten
Wrench tighten all hardware in this step.

Step 15 Leg Extension Cable Routing

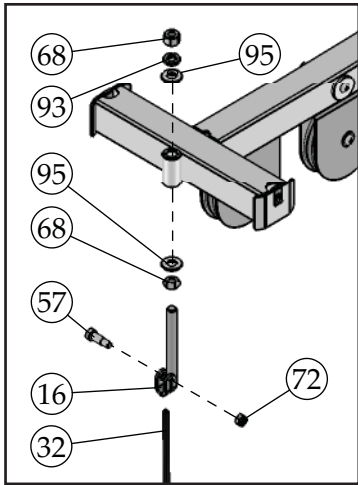

NOTE:

1. SOME PARTS CUT OUT/NOT SHOWN FOR CLARITY.
2. ASSEMBLE PULLEYS (#44, #45) SHOWN ON THIS STEP UNTILL CABLE IS COMPLETELY ROUTED AND SECURED.
3. TIE CABLE END TO GUIDE WIRE AT LOCATION INDICATED BELOW.
4. CAREFULLY PULL THE GUIDE WIRE OUT THROUGH ITEM #4.
5. DISCARD THE GUIDE WIRE ONCE YOU'VE RUNNED THE CABLE OUT OF THE FRAME.
6. ASSEMBLE PULLEYS (#44, #45) AND MAKE ANY NECESSARY ADJUSMENTS ON THE ADJUSTABLE CABLE BRACKET #16.
7. MAKE SURE TO TIGHTEN SCREW #91.

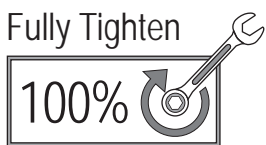
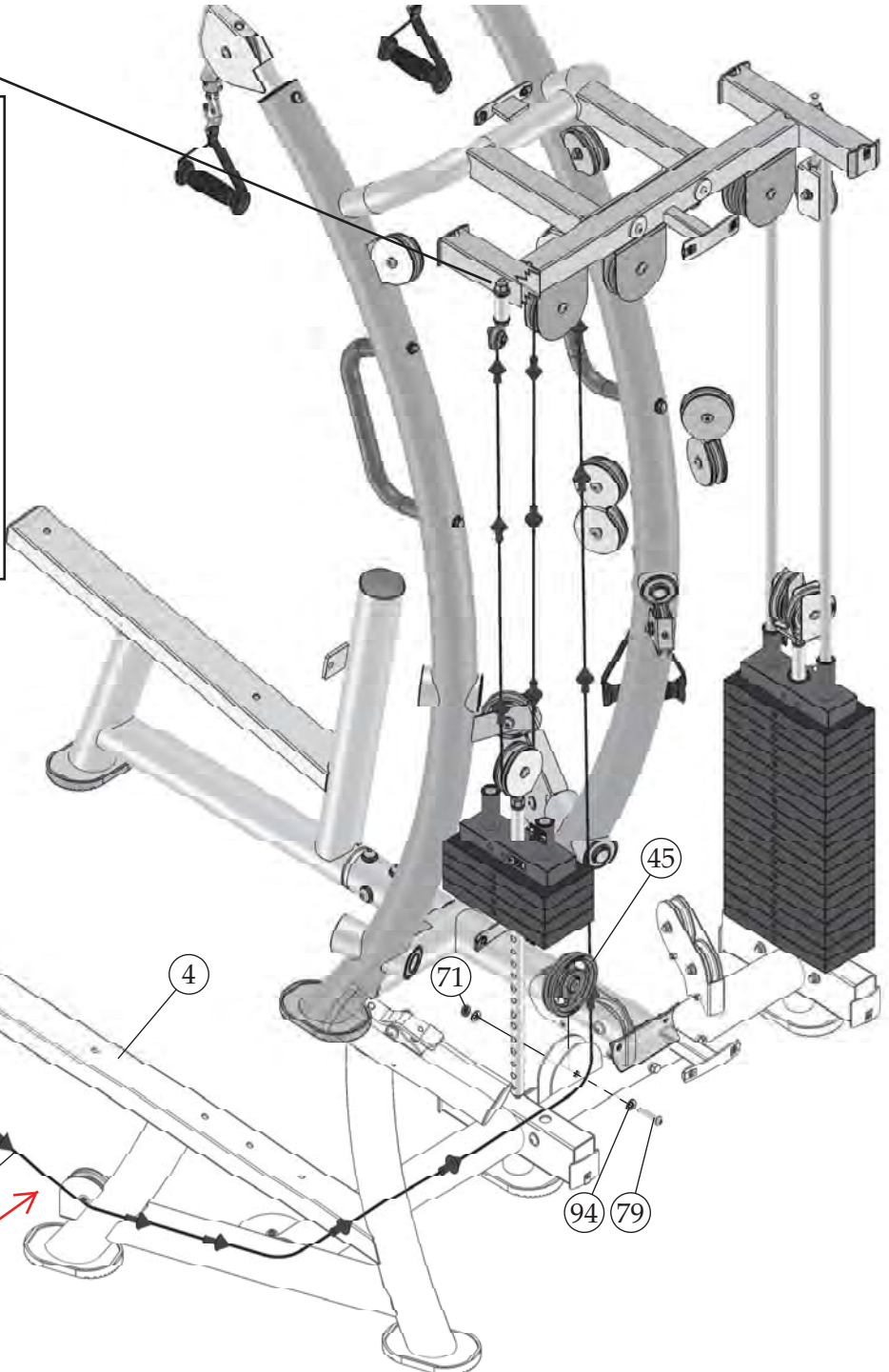
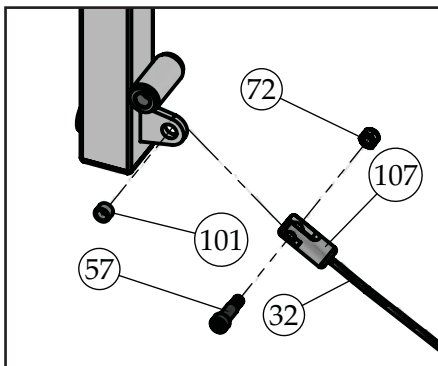
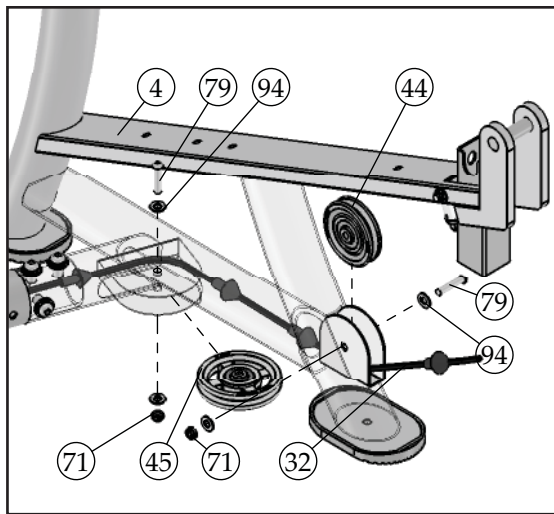

Fully Tighten
Wrench tighten all hardware in this step.

TIE CABLE AND WIRE

Step 16

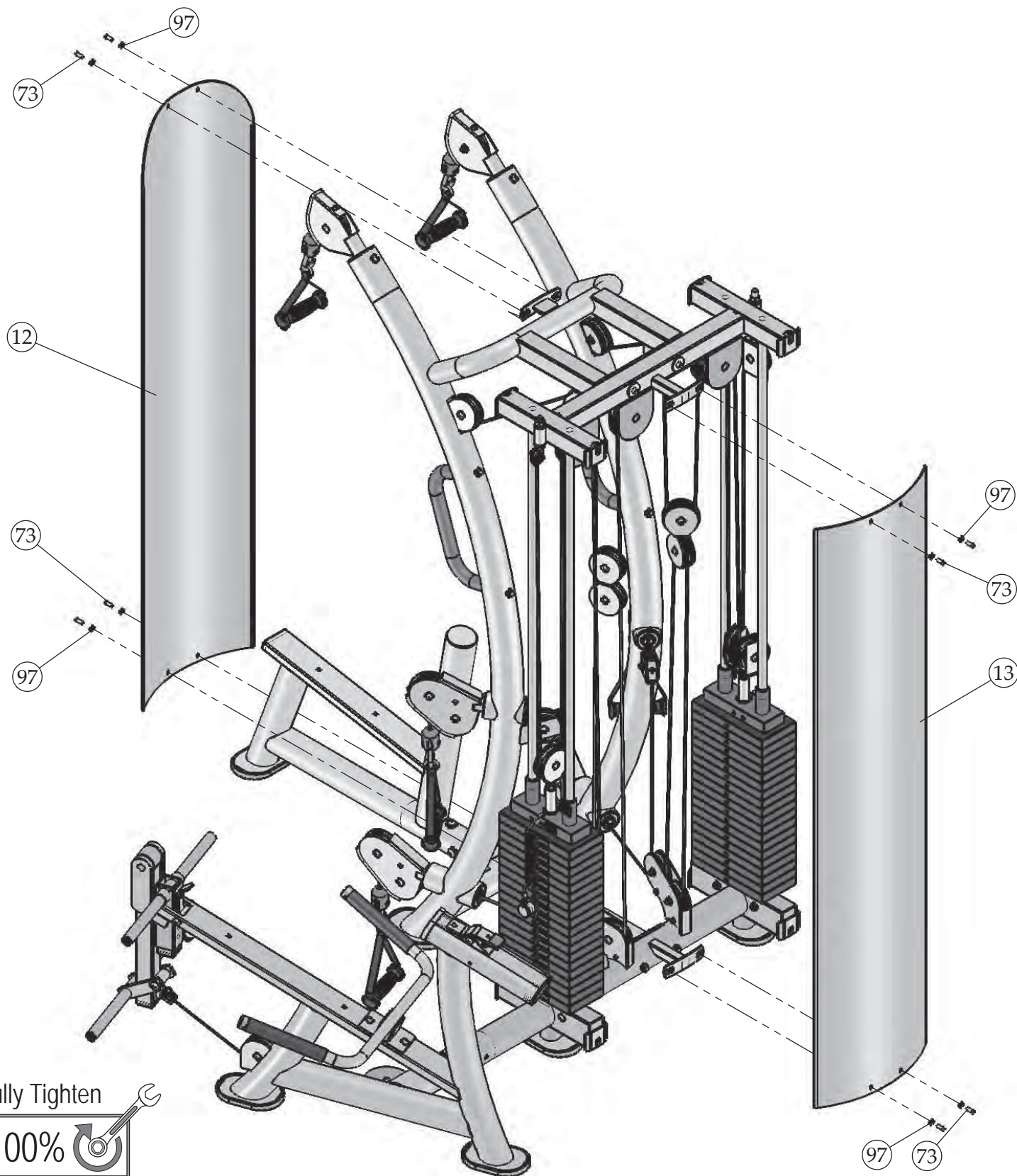

Fully Tighten

100%



Fully Tighten

Wrench tighten all hardware in this step.

Step 17

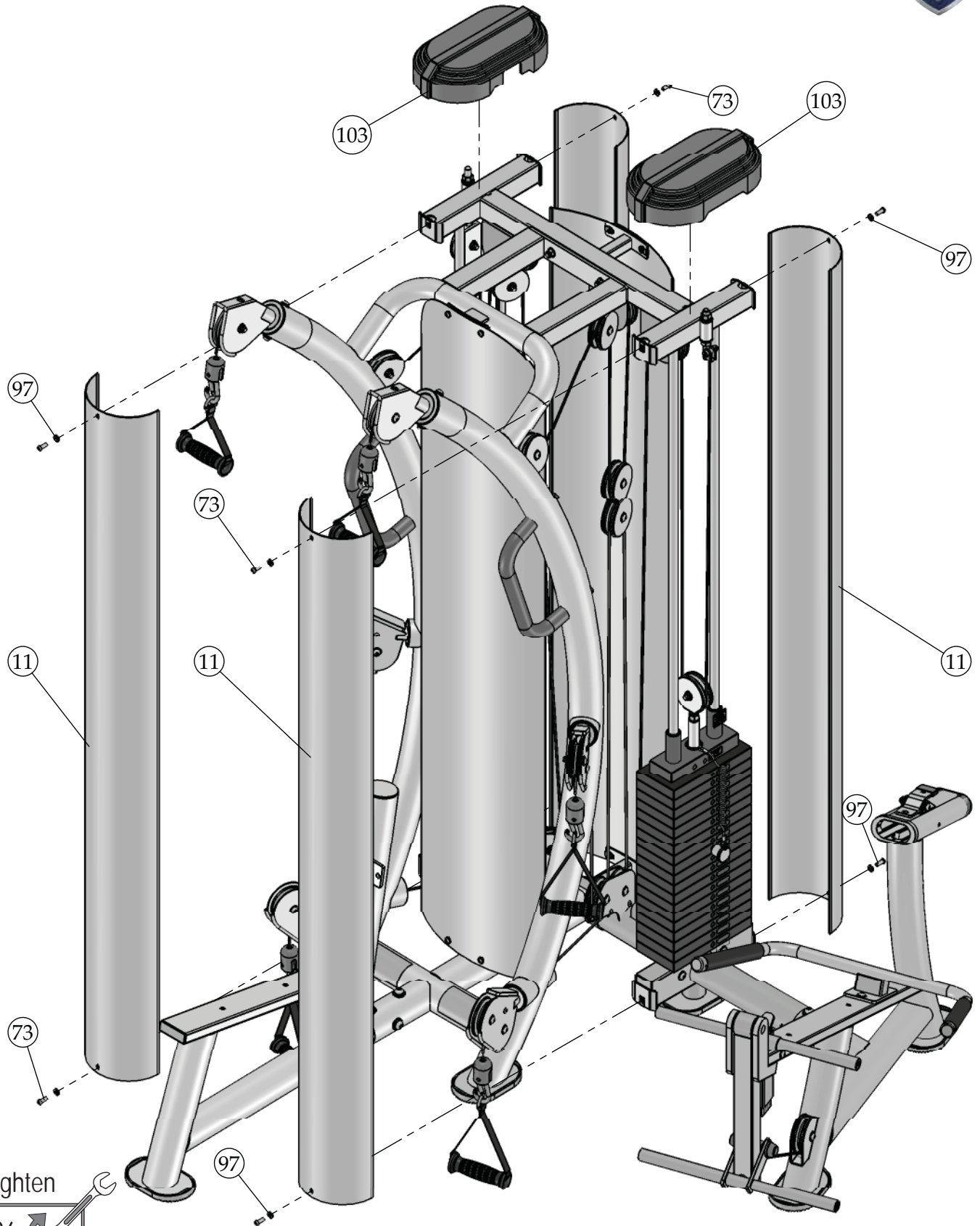

Fully Tighten



Fully Tighten

Wrench tighten all hardware in this step.

Step 18

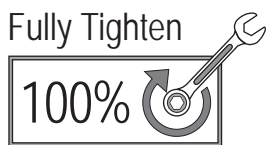
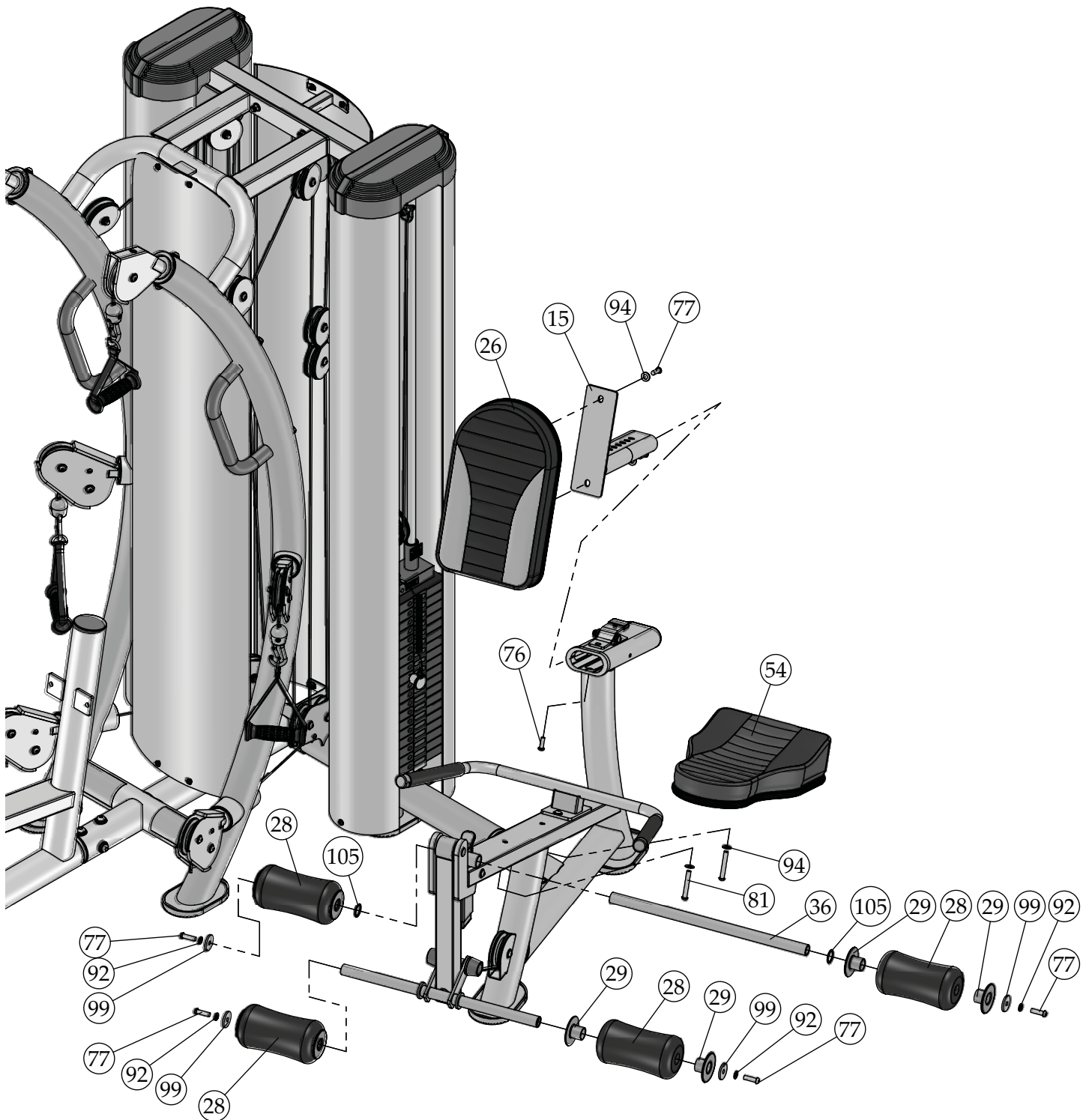

Fully Tighten
Wrench tighten all hardware in this step.

Step 19

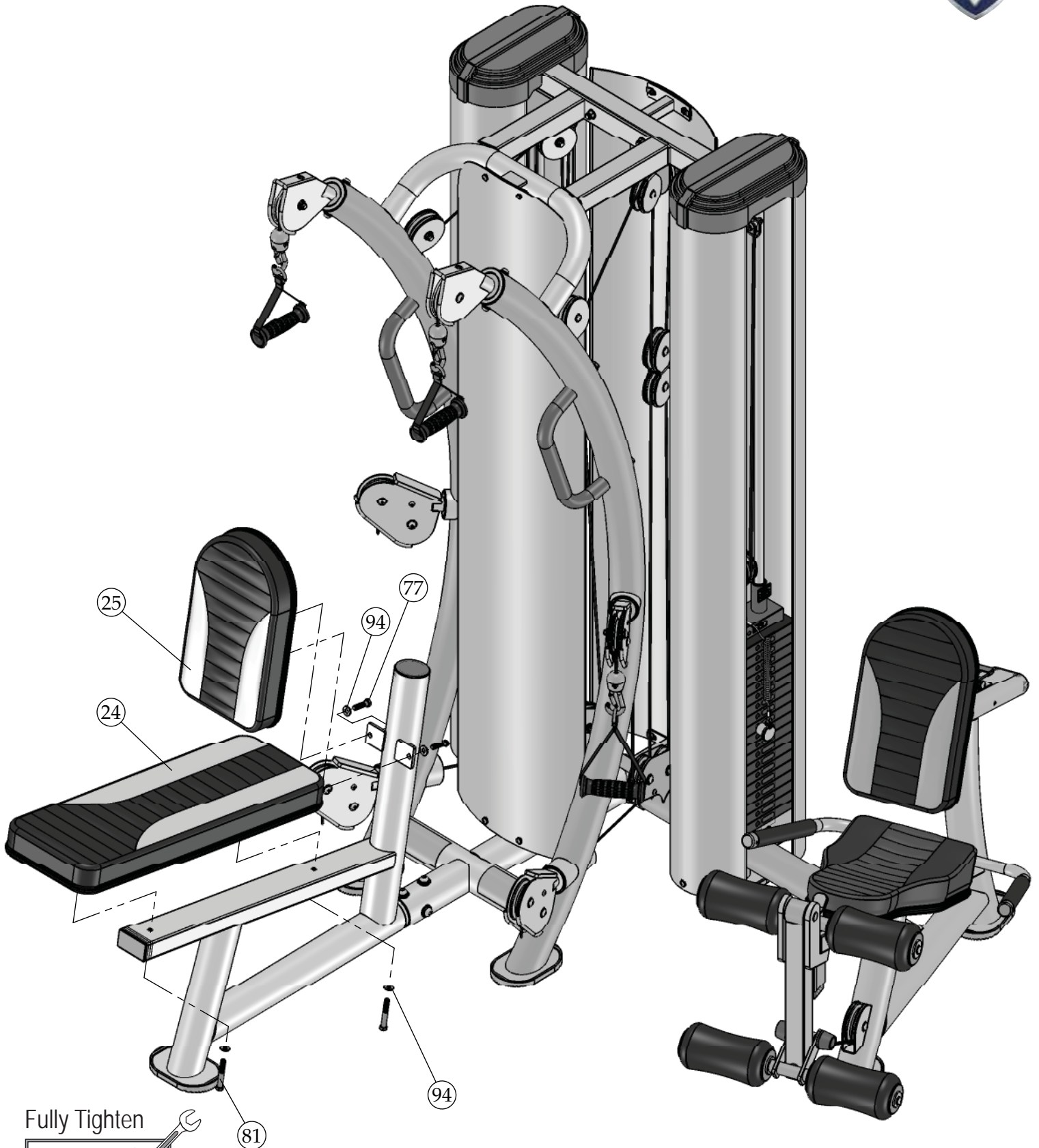

Fully Tighten



Fully Tighten

Wrench tighten all hardware in this step.

Parts List



COLOR CHART
 GRAY= SUB-ASSEMBLY PARTS
 BLACK=HARDWARE

HTX-2000 Parts List

REV1

Item No.	Description	Rev	Part No.	Qty.	Item No.	Description	Part No.	Qty.
1	MAIN FRAME	0	UP6816	1	67	BALL BEARING R20-RS (4 I.D. X 2 1/4 X 1/2)	BNH1712	12
2	BENCH FRAME	0	UP6801	1	68	FINISHED HEX NUT Z/P 1/2-13	BNH0206	6
3	REAR BASE FRAME	0	UP6817	1	69	NYLON INSERT LOCK NUT B-Z/P 1/4-20	BNH2502	8
4	LEG EXTENSION BENCH FRAME	0	UP6811	1	70	NYLON INSERT THIN PATTERN LOCK NUT Z/P 1/2-13	BNH2027	1
5	LOCKING LEVER, ADJ FOAM ROLL FRAME	0	UP6815	1	71	NYLON INSERT LOCK NUT Z/P 3/8-16	BNH2028	47
6	TOP GUIDE ROD HOUSING	0	UP6822	1	72	NYLON INSERT LOCK NUT Z/P 5/16-18	BNH2056	2
7	LEG EXTENSION HANDLES	0	UP6812	1	73	BUTTON HEAD SOCKET CAP SCREW GR-8 B-Z/P 1/4-20 X 3/4	BNH2447	16
8	LEG EXT PIVOT ARM	0	UP6809	1	74	BUTTON HEAD SOCKET CAP SCREW GR-8 B-Z/P 1/4-20 X 1 1/2	BNH4002	8
9	LEX EXT FOOT ROLL FRAME	0	UP6814	1	75	BUTTON HEAD SOCKET CAP SCREW B-Z/P 3/8-16 X 3/4	BNH2592	4
10	GUIDE ROD 3/4 X 67 3/4	0	UP6808	4	76	BUTTON HEAD SOCKET CAP SCREW GR-8 B-Z/P 3/8-16 X 1	BNH2528	2
11	WEIGHT SHIELD	0	UP6821	4	77	BUTTON HEAD SOCKET CAP SCREW GR-8 Z/P 3/8-16 X 1 1/4	BNH2034	8
12	FRONT WEIGHT SHIELD	0	UP6819	1	78	RELEASE LEVER PROTECTIVE COVER	BNH3201	1
13	REAR WEIGHT SHIELD	0	UP6820	1	79	BUTTON HEAD SOCKET CAP SCREW B-Z/P 3/8-16 X 1 3/4	BNH2590	33
14	CHROME, ADJ FOAM ROLL FRAME	0	UP6806	1	80	HTX-2000 EXERCISE DVD	BNH3090	1
15	CHROME, ADJ BACK PAD FRAME	0	UP6805	1	81	SOCKET CAP SCREW GR-8 Z/P 3/8-16 X 2 1/2	BNH2365	11
16	ADJUSTABLE CABLE BRACKET	0	UP0591	1	82	RUBBER HANDLE, 1 ID, 0.125T, 8 L	BNH0966	2
17	FLOATING DOUBLE 3 1/2 PULLEY BRACKET LT	0	UP6807	1	83	SOCKET CAP SCREW GR-8 Z/P 3/8-16 X 3 3/4	BNH2372	1
18	ADJUSTABLE 3 1/2 PULLEY BRACKET	0	UP6800	1	84	SOCKET CAP SCREW GR-8 Z/P 3/8-16 X 4	BNH2374	2
19	TOP PLATE 3 1/2 PULLEY BRACKET	0	UP6823	1	85	SOCKET CAP SCREW GR-8 Z/P 3/8-16 X 3	BNH3202	3
20	TOP PLATE DOUBLE 3 1/2 PULLEY BRACKET	0	UP6824	1	86	SOCKET CAP SCREW GR-8 Z/P 3/8-16 X 4 1/4	BNH2376	4
21	TOP SWIVEL PULLEY BRACKET	0	UP3634	2	87	BUTTON HEAD SOCKET CAP SCREW GR-8 B-Z/P 1/2-13 X 1	BNH2401	8
22	SHORT DOUBLE SWIVEL PULLEY BRKT	0	UP6182	2	88	BUTTON HEAD SOCKET CAP SCREW GR-8 B-Z/P 1/2-13 X 3 3/4	BNH2408	1
23	LONG DOUBLE SWIVEL PULLEY BRKT	0	UP6173	2	89	PIVOT AXLE 3/4 X 3	UP7718	1
24	SEAT PAD	0	UP6825	1	90	SOCKET SET SCREW B-Z/P 10-32 X 1/8	BNH2518	5
25	BACK PAD	0	UP6826	1	91	OVAL HEAD PHILLIPS MACHINE SCREW Z/P #10-32 X 1 1/8	BNH2793	6
26	LEG EXTENSION BACK PAD	0	UP6810	1	92	SPLIT LOCK WASHER B-Z/P 3/8"	BNH2032	12
27	HANDLE	0	UP7075	2	93	SPLIT LOCK WASHER B-Z/P 1/2"	BNH2519	12
28	FOAM FOOT ROLL 1 X 4 X 7 W/VINYL	0	UP3785	4	94	FLAT WASHER SAE B-Z/P 3/8"	BNH2524	104
29	ALUMINUM FOOT ROLL END CAP		BNH3204	8	95	FLAT WASHER SAE B-Z/P 1/2"	BNH2523	14
30	CONTOUR ERGO HANDLE SHORT STRAP		BNH2739	2	96	SOCKET SET SCREW ALLOY 1/4-20 X 1/4	BNH0790	2
31	10 LB STEEL WEIGHT PLATE BLACK 4 9/16 X 9 7/16 ASSY		BNH1650	38	97	FLAT SAE WASHER B-Z/P #12	BNH4008	16
32	CABLE, LEG EXTENSION (HTX-2000)	0	UP6803	1	98	BRONZE BUSHING W/FLANGE 3/4" 102118-FF-1015-1	BNH0243	2
33	CABLE, LAT (HTX-2000)	0	UP6802	1	99	ALUMINUM WASHER .390 ID X 1.500 OD X .150 THK	BNH1541	4
34	CABLE, LOW ROW (HTX-2000)	0	UP6804	2	100	FLOATING DOUBLE 3 1/2 PULLEY BRACKET RT	UP6654	1
35	TOP BEARING HOUSING	0	UP6166	2	101	BRONZE BUSHING 10 MM X 14 MM X 5 MM	BNH3205	1
36	FOOT ROLL TUBE 1 X 19 1/2	0	UP7717	1	102	RUBBER FLAT TUBE .94 ID X .115 WALL X 19	BNH2485	2
37	CABLE STOPPER SHELL 1 1/2 X 1 3/4		BNH4230	6	103	WEIGHT STACK LID (2" SQ. NOTCH)	BNH4108	2
38	7/8 RD X 1 5/8 LINK 1/8 CABLE		BNH4231	6	104	SUPER LUBE TEFLON LUBRICANT 82340	BNH0704	1
39	CONTOUR ERGO HANDLE LONG STRAP		BNH2738	4	105	NYLON FLAT WASHER 1 X 1 1/4 X 1/16	BNH0393	4
40	PLASTIC INSERT CAP 1 3/4" SQ 10-14 GA		BNH0053	2	106	PLASTIC OPEN END CAP BLACK-BUMPER (1/2 BOLT)	BNH3241	2
41	CHROME WASHER 3/8 X 1 1/2		BNH1015	4	107	CLEVIS BRACKET 3/16"	BNH0076	1
42	ALUMINUM CAP 1.020" RD (CAP-100)		BNH0537	2	108	PLASTIC INSERT CAP 3 RD	BNH3240	1
43	SELECTOR PIN W/COIL 3/8 X 4 GOLD KNOB	0	UP3035	2	109	YELLOW RUBBER GRIP	BNH3242	1
44	BLACK NYLON PULLEY 3/8 X 1 X 3 1/2 (P-35375-H)		BNH0553	27	110	HEX KEY LONG ARM ALLOY 3/16"	BNH0371	1
45	NYLON PULLEY 3/8 X 1 X 4 1/2 BLACK		BNH0069	8	111	HEX KEY ALLOY 7/32"	BNH0575	1
46	U-STYLE TAPPED HOLE NUT 1/4-20		BNH0708	16	112	LABEL-DANGER CHECK RETAINING NUT...	BNH3146	1
47	10 LB TOP PLATE W/ADJ SLTR BAR 19 BLK WTS ASSY		BNH1982	2	113	LABEL-DANGER USE THIS EQUIPMENT...	BNH3088	1
48	RUBBER FOOT FOR 6 X 4 1/4 PLATE		BNH1647	7	114	LABEL DANGER DO NOT LEAN AGAINST OR PULL...	BNH2955	2
49	RUBBER GROMMET 3/4" ID (2867-012)		BNH0401	4	115	LABEL-WARNING KEEP BODY, HANDS, 1 1/2 X 2 1/4	BNH2908	1
50	SAFETY TAPE ANTI-SLIP 125MM X 125MM		BNH3200	2	116	LABEL-WARNING KEEP BODY, HANDS...	BNH2926	2
51	PLASTIC INSERT CAP ELLIPTICAL 2 X 4		BNH1794	1	117	HEX KEY ALLOY 5/32"	BNH0373	1
52	PULL PIN NUT 25/64 X 3/4-10 K-103		BNH0181	1	118	LABEL-WARNING SERIOUS INJURY OR DEATH	BNH3134	1
53	RELEASE LEVER, SPRING ACTUATED	0	UP6818	1	119	LABEL-CAUTION CHECK PULL-PIN IS FULLY...	BNH2912	1
54	LEG EXTENSION SEAT PAD	0	UP6813	1	120	LABEL-WARRANTY LIGHT COMMERCIAL	BNH3136	1
55	PLASTIC INSERT ELLIPTICAL GUIDE (2X4)		BNH1760	1	121	LABEL-INSPECTIONS RECOMMENDED INSPECTION...	BNH3137	1
56	NYLON ANKLE STRAP		BNH3203	1	122	LABEL-SCHEDULE REPLACEMENT PARTS...	BNH3135	1
57	SHOULDER BOLT ALLOY 3/8 X 3/4		BNH0718	2	123	LABEL-IMPORTANT ADJUST CABLE TENSION HERE	BNH2924	2
58	PULL PIN AXLE 2 3/4 X 1/2 K-101A		BNH0866	1	124	LABEL-IMPORTANT FOR SMOOTH PERFORMANCE...	BNH2925	2
59	SNAP LINK Z/P 8MM X 80MM		BNH0065	6	125	LABEL-IMPORTANT FOR SMOOTH PERFORMANCE...	BNH2916	2
60	BRONZE BUSHING 1/2 X 5/8 X 1/2 X 7/8 X 1/8		BNH0528	2	126	FACILITY SIGN BE ALERT! THE FITNESS EQUIPMENT...	BNH3002	1
61	RUBBER DONUT 3/4 X 2 1/2		BNH0068	4	127	TFI EMBLEM 1.88 HIGH X 1.98 WIDE BLUE AND CHROME	BNH4304	1
62	URETHANE BUMPER .500 X .975 X .276 X .122		BNH4106	2	128	LABEL-TFI SERIAL NO.	BNH3147	1
63	LABEL EXERCISE GUIDE		BNH3049	1	129	LABEL NUMBERS 10-200 LBS/KGS	BNH4069	2
64	PULL PIN STIFF SPRING 17/32 X 1 1/2 K-105SS		BNH0519	2	130	HEX KEY ALLOY 5/16"	BNH0374	1
65	PLASTIC INSERT CAP 40mm X 80mm		BNH3239	1	131	HEX KEY LONG ARM ALLOY 1/8"	BNH0767	1
66	RETAINING SNAP RING EXT. PLAIN 1 1/4"		BNH1718	6				

Basic Exercise Guide



Use this equipment only for the exercises as shown. Know your limitations. If you are new to weight training, always start with lighter weight, learn how to perform the exercise correctly and train at a controlled rate of speed. Warm up properly with stretchings, calisthenics or cardiovascular exercises. Never hold your breath – general rule of thumb is to exhale when you exert. For additional recommended exercises please refer to DVD.

WARNING Before working out, read and understand the Owner's Manual, all danger, warning and caution labels listed on pages 4-7. This equipment is for LIGHT COMMERCIAL use only. Obtain a medical examination before beginning any exercise program. If you feel faint, dizzy or pain, stop exercising immediately.



TRICEP PRESSDOWN

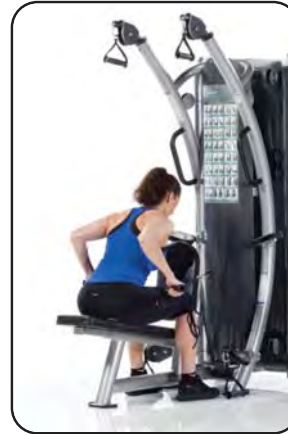

TRICEP KICKBACK

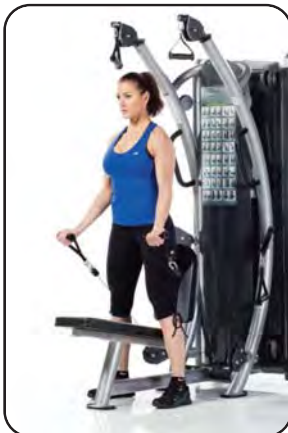

BICEP CURL

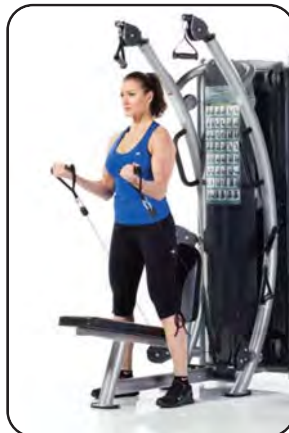

OVERHEAD CURL

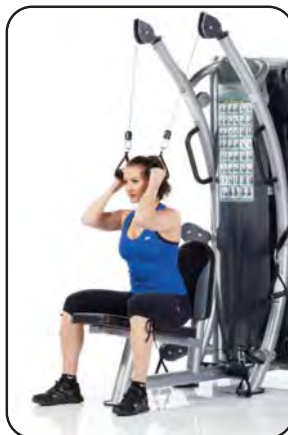
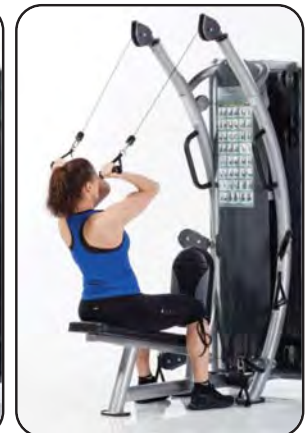

AB CRUNCH

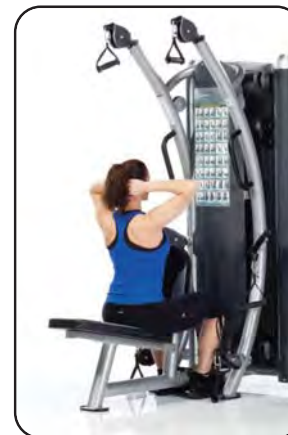
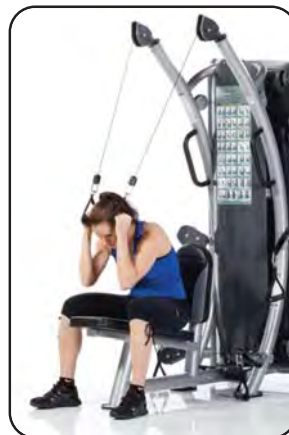

SIT UPS

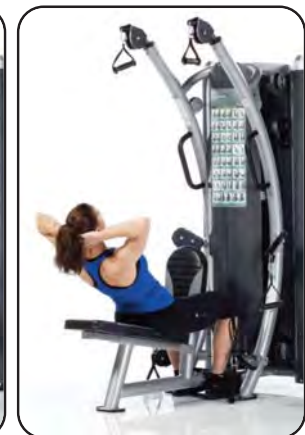



Basic Exercise Guide

Use this equipment only for the exercises as shown. Know your limitations. If you are new to weight training, always start with lighter weight, learn how to perform the exercise correctly and train at a controlled rate of speed. Warm up properly with stretchings, calisthenics or cardiovascular exercises. Never hold your breath – general rule of thumb is to exhale when you exert. For additional recommended exercises please refer to DVD.

⚠ WARNING Before working out, read and understand the Owner's Manual, all danger, warning and caution labels listed on pages 4-7. This equipment is for LIGHT COMMERCIAL use only. Obtain a medical examination before beginning any exercise program. If you feel faint, dizzy or pain, stop exercising immediately.



CORE ROTATION

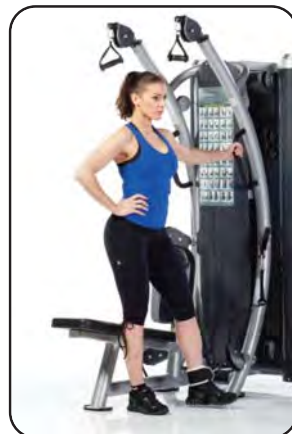

INNER THIGH

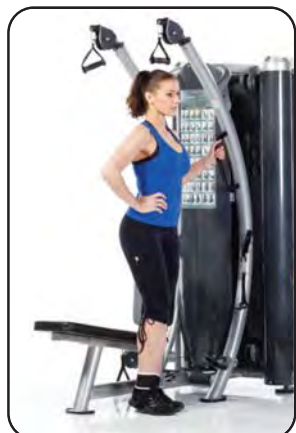

OUTER THIGH

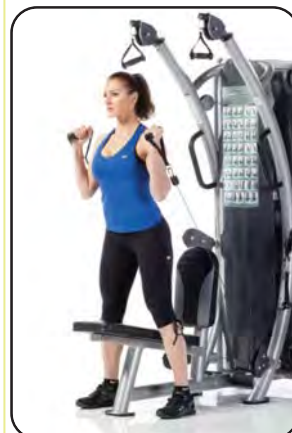

SQUATS

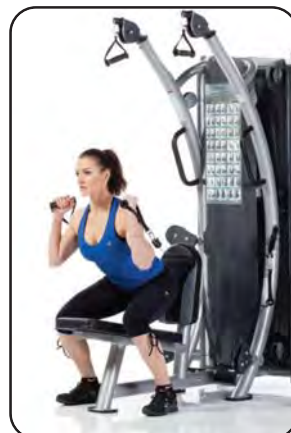

LEG EXTENSION



STANDING LEG CURL



Basic Exercise Guide



Use this equipment only for the exercises as shown. Know your limitations. If you are new to weight training, always start with lighter weight, learn how to perform the exercise correctly and train at a controlled rate of speed. Warm up properly with stretchings, calisthenics or cardiovascular exercises. Never hold your breath – general rule of thumb is to exhale when you exert. For additional recommended exercises please refer to DVD.

⚠ WARNING

Before working out, read and understand the Owner's Manual, all danger, warning and caution labels listed on pages 4-7. This equipment is for LIGHT COMMERCIAL use only. Obtain a medical examination before beginning any exercise program. If you feel faint, dizzy or pain, stop exercising immediately.



CHEST PRESS



CHEST FLY



CROSSOVER

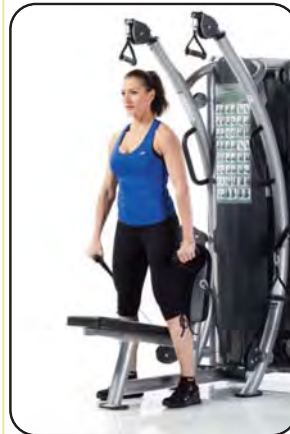

OFFER UPS



LAT PULLDOWN



IRON CROSS PULLDOWN

Basic Exercise Guide



Use this equipment only for the exercises as shown. Know your limitations. If you are new to weight training, always start with lighter weight, learn how to perform the exercise correctly and train at a controlled rate of speed. Warm up properly with stretchings, calisthenics or cardiovascular exercises. Never hold your breath – general rule of thumb is to exhale when you exert. For additional recommended exercises please refer to DVD.

⚠ WARNING Before working out, read and understand the Owner's Manual, all danger, warning and caution labels listed on pages 4-7. This equipment is for LIGHT COMMERCIAL use only. Obtain a medical examination before beginning any exercise program. If you feel faint, dizzy or pain, stop exercising immediately.

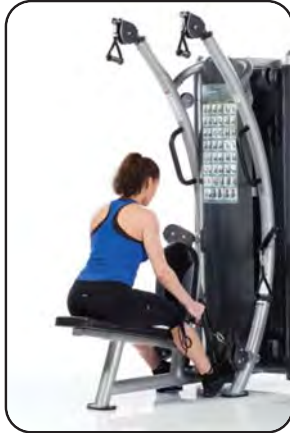

SEATED ROW

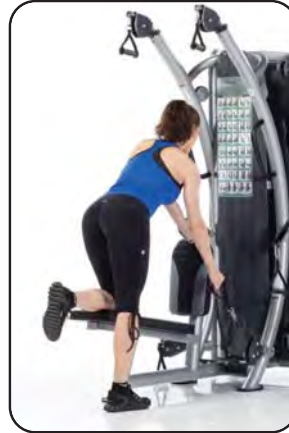

ONE ARM ROW

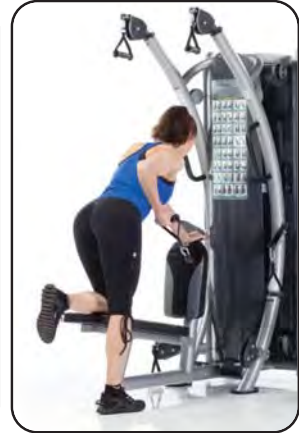

UPRIGHT ROW

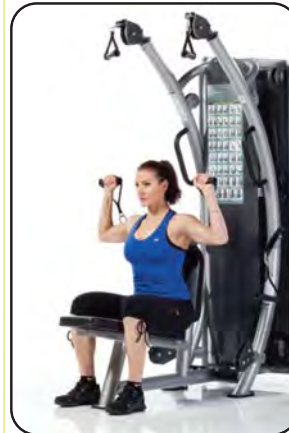

SHOULDER PRESS

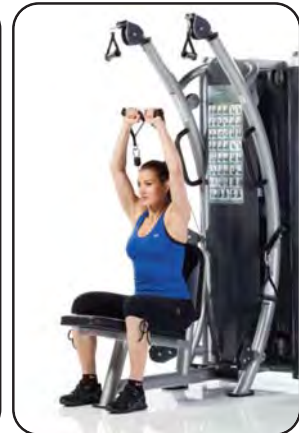

LATERAL RAISE



TRICEP EXTENSION





LIGHT COMMERCIAL WARRANTY

This warranty applies only in the United States to the products manufactured or distributed by TuffStuff Fitness International (TFI) under the TuffStuff brand name. TFI warrants to the original purchaser that TuffStuff equipment will be free from defects in material and workmanship. All warranty periods begin to run from the date of purchase to the original purchaser. The warranty and remedies set forth herein are conditioned upon proper storage, installation, use and maintenance and conformance with any recommendations of TFI. This warranty does not cover products not manufactured by TFI or products which are altered without the express written consent of TFI.

LIGHT COMMERCIAL WARRANTY:

- TEN (10) Years:** Structural main frames, welds, cams and weight plates.
- FIVE (5) Years:** Pivot bearings, pulleys, bushings, guide rods and gas shocks.
- ONE (1) Year:** Belts, linear bearings and pull-pin components.

All other parts not mentioned elsewhere in the warranty will expire one (1) year from the date of purchase to the original purchaser.

- SIX (6) Months:** Upholstery, cables, finish and rubber grips.

HOME LIFETIME WARRANTY:

LIFETIME of the equipment while owned by the original purchaser (applies only to defects from manufacturer only).

This warranty does not cover:

1. TuffStuff products sold for and used in a commercial or institutional environment.
2. Any damage, failure or loss caused by accident, misuse, neglect, abuse, improper assembly, improper maintenance, or failure to follow instructions or warnings in the owner's manual and warning labels posted on the machines.
3. Use of the product in a manner for which it was not designed.
4. Original product that is altered, or the use of replacement parts and components of another manufacturer other than TuffStuff.

Light Commercial Use:

Light Commercial Warranty applies to facilities like hotels, apartment complexes, personal training studios, fire & police stations, etc. where the equipment would be used by no more than 30 people per day.

The obligation of TFI under this warranty is limited to repairing or replacing warranted defective parts as TFI may elect, at TFI's facility in Chino, California, without charge to the purchaser. Purchaser is responsible for installation of repaired or replaced parts, and all transportation and insurance costs on returned or replaced equipment to and from TFI's facility in Chino.

THE FOREGOING SHALL CONSTITUTE THE SOLE REMEDY OF THE PURCHASER AND THE SOLE LIABILITY OF TFI WITH REGARD TO WARRANTY. NO IMPLIED STATUTORY WARRANTY OR IMPLIED STATUTORY WARRANTY OF MERCHANTABILITY OR FITNESS FOR A PARTICULAR PURPOSE SHALL APPLY. IN NO EVENT, WHETHER AS A RESULT OF BREACH OF CONTRACT, WARRANTY, NEGLIGENCE OR OTHERWISE, SHALL TFI BE LIABLE FOR SPECIAL, INCIDENTAL OR CONSEQUENTIAL DAMAGES INCLUDING, BUT NOT LIMITED TO, LOSS OF PROFITS OR REVENUE, LOSS OF USE OF EQUIPMENT, COST OF CAPITAL, COST OF SUBSTITUTION EQUIPMENT, DOWNTIME COST, OR CLAIMS OF CUSTOMERS OR PURCHASER FROM SUCH DAMAGE.

This written warranty is the final, complete and exclusive agreement of the parties with respect to the quality or performance of the equipment and no action for breach of this written warranty or any implied warranty shall be commenced more than one (1) year after the accrual of the cause of action. No modification of this warranty or waiver of its terms shall be binding on either party unless approved in writing by an authorized representative of the party. Contact TuffStuff Fitness International at 13971 Norton Avenue, Chino, CA 91710, before returning any defective equipment.

This warranty gives you specific legal rights and you may also have other rights, which may vary from state to state.

SERIAL #

Write your Serial number here for future reference

Purchase Date



TuffStuff Fitness International, Inc.

13971 Norton Avenue, Chino, CA 91710, USA Phone: 909-629-1600 Fax: 909-629-4967
www.tuffstufffitness.com service@tuffstuff.net or service1@tuffstuff.net

Exploded View

